

19 SERIES
Switching actuators



Building
and house
automation



Energy
efficiency



Control
shutters



Control
curtains / blinds

3 channel switching actuator with KNX technology for shutters and blinds Type 19.3K.9.030.4300

3 channel switching actuator for use with electric / electronic motors.
For the management of curtains, shutters and blinds.

- Rated 16 A, standard contact material AgSnO₂
- 35 mm rail (EN 60715) mount
- 72 mm wide (4 modules)



NEW



3 channel switching actuator with KNX technology for shutters and blinds
Type 19.3K.9.030.4300

- Bistable relay ENEC approved (Maximum peak current up to 120 A)
- Supply voltage via KNX Bus
- Controls up to 3 electric motors
- Logic outputs
- Logically interlocked outputs
- Management of 3 blinds
- Nominal consumption <15 mA

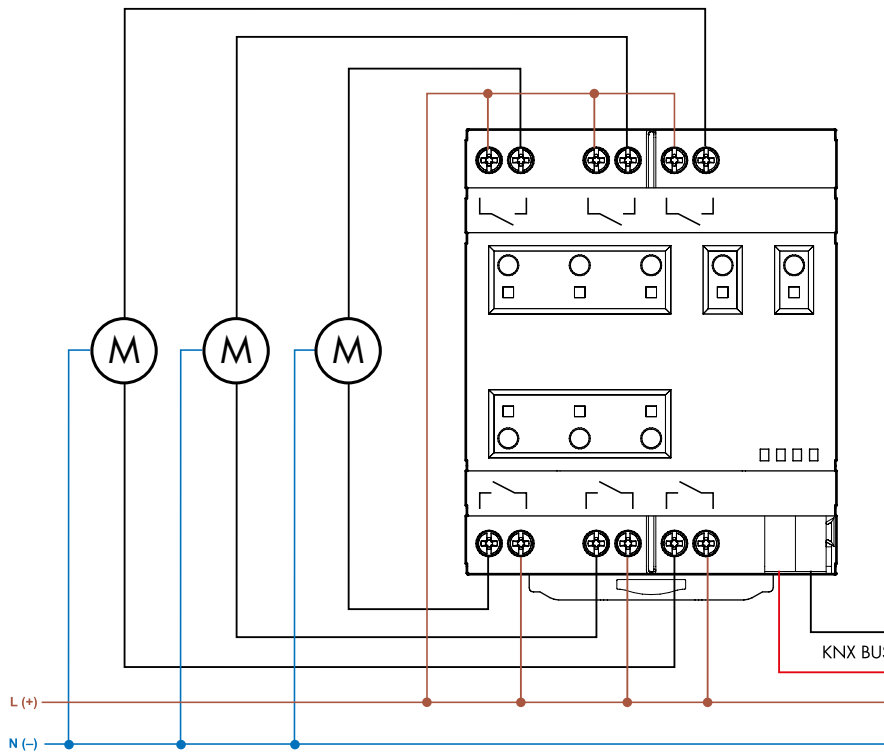

Prices, features, specifications, capabilities, appearance and availability of our products and services are subject to change without notice. FINDER assumes no responsibility for the presence of possible errors or insufficient information in this document. In case of discrepancies between the printed and online versions, the latter prevails.



The **KNX bus system** and standard allows the realisation of flexible control systems to achieve energy-efficiency and comfort in the home or commercial buildings.

- KNX** complies with:
- Standard Europeo (CENELEC EN 50090 e CEN EN 13321-1)
 - Standard Internazionale (ISO/IEC 14543-3)
 - Standard Cinese (GB/T 20965)
 - Standard US (ANSI/ASHRAE 135)