

Relay modules with forcibly guided contacts 6 A

7S
SERIES



Door control



Signalling



Doors
opening/closing



Relay module with forcibly guided contacts

Type 7S.12/32T

- 2 pole 6 A (1 NO + 1 NC)

Type 7S.14/34T

- 4 pole 6 A (2 NO + 2 NC and 3 NO + 1 NC)

Type 7S.16/36T

- 6 pole 6 A (4 NO + 2 NC)

- For railway application; materials compliant with EN 45545-2:2020 (protection against fire of materials), EN 61373 (resistance against random vibrations and shock, Category 1, Class B), EN 50155 (resistance to temperature and humidity, OT4/ST1 class)
- For safety applications, with class A forcibly guided contact relays EN 61810-3 (ex EN 50205)
- For functional reliability in machinery and plant engineering according to EN 13849-1
- DC and AC supply versions
- 24 and 110 V DC versions with extended operating range $(0.7 \dots 1.25)U_N$
- Coil status visual indication with LED
- 35 mm rail (EN 60715) mount

7S.xx

Screwless terminal



* Short term (10 min) +85°C

For outline drawing see page 8

7S.12/32...5110T



• 2 pole (1 NO + 1 NC)

7S.14/34...4220/4310T



• 4 pole (2 NO + 2 NC and 3 NO + 1 NC)

7S.16/36...5420T



• 6 pole (4 NO + 2 NC)

Contact specification

Contact configuration		1 NO + 1 NC	2 NO + 2 NC, 3 NO + 1 NC	4 NO + 2 NC
Rated current/Max. peak current	A	6/15	6/15	6/15
Rated switching voltage	V AC (50/60 Hz)	250	250	250
Rated load AC1	VA	1500	1500	1500
Rated load AC15 (230 V AC)	VA	700	700	700
Breaking capacity DC1: 24/110/220 V	A	6/0.6/0.2	6/0.9/0.3	6/0.9/0.3
Breaking capacity DC13: 24 V	A	1	3	5
Minimum switching load	mW (V/mA)	60 (5/5)	60 (5/5)	60 (5/5)
Standard contact material		AgNi + Au	AgSnO ₂	AgSnO ₂ +Au

Coil specification

Nominal voltage (U_N)	V AC (50/60 Hz)	110...125 - 230...240	110...125 - 230...240	110...125 - 230...240
	V DC	24	24 - 110	24 - 110
Rated power	VA (50 Hz)/W	2.3/1	2.3/1	2.3/1
Operating range	AC	$(0.85 \dots 1.1)U_N$	$(0.85 \dots 1.1)U_N$	$(0.85 \dots 1.1)U_N$
	DC	—	—	—
DC extended range (24 and 110 V only)		$(0.7 \dots 1.25)U_N$	$(0.7 \dots 1.25)U_N$	$(0.7 \dots 1.25)U_N$
Holding voltage	AC/DC	$0.45 U_N / 0.45 U_N$	$0.55 U_N / 0.55 U_N$	$0.55 U_N / 0.55 U_N$
Must drop-out voltage	AC/DC	$0.1 U_N / 0.1 U_N$	$0.1 U_N / 0.1 U_N$	$0.1 U_N / 0.1 U_N$

Technical data

Mechanical life	cycles	$10 \cdot 10^6$	$10 \cdot 10^6$	$10 \cdot 10^6$
Electrical life at rated load AC1	cycles	$100 \cdot 10^3$	$100 \cdot 10^3$	$100 \cdot 10^3$
Operate/release time	ms	7/11	12/10	12/10
Insulation between coil and contacts (1.2/50 μ s)	kV	6	6	6
Dielectric strength between open contacts	V AC	1500	1500	1500
Ambient temperature	°C	-40...+70*	-40...+70*	-40...+70*
Protection category		IP 20	IP 20	IP 20

Approvals (according to type)



Ordering information

Example: 7S series Relay module with forcibly guided contacts, 6 contact (4 NO + 2 NC) 6 A, supply voltage 24 V DC.

7 S . 1 6 . 9 . 0 2 4 . 5 4 2 0 T

- Series** —————
- Type** —————
1 = 22.5 mm wide, cage-clamp terminals
- Output** —————
2 = 2 contacts
4 = 4 contacts
6 = 6 contacts
- Supply version** —————
8 = AC (50 /60 Hz)
9 = DC
- Supply voltage** —————
See page 7

- Special versions**
0 = Standard
- NO and NC contacts**
11 = 1 NO + 1 NC
22 = 2 NO + 2 NC
31 = 3 NO + 1 NC
42 = 4 NO + 2 NC
- Contact material**
4 = AgSnO₂ (7S.14 only)
5 = AgNi + Au (7S.12 only)
5 = AgSnO₂ + Au (7S.16 only)

Technical data

Insulation according to EN 61810-1					
Nominal voltage of supply system	V AC	230/400			
Rated insulation voltage	V AC	250			
Pollution degree		2			
Insulation between coil and contact set					
Type of Insulation		Reinforced			
Overtoltage category		III			
Rated impulse voltage	kV (1.2/50 µs)	6			
Dielectric strength	V AC	4000			
Insulation between adjacent contacts					
Type of Insulation		Basic			
Overtoltage category		III			
Rated impulse voltage	kV (1.2/50 µs)	4			
Dielectric strength	V AC	2500			
Insulation between open contacts					
Type of disconnection		Micro-disconnection			
Dielectric strength	V AC/kV (1.2/50 µs)	1500/2.5			
Insulation between coil terminals					
Rated impulse voltage (surge) differential mode (according to EN 50121)	kV (1.2/50 µs)	1.5			
Terminals		solid cable	stranded cable		
Max. wire size	mm ²	1 x 1.5	1 x 1.5		
	AWG	1 x 14	1 x 16		
Wire strip length	mm	9			
Other data		7S.12	7S.14	7S.16	
Bounce time: NO/NC	ms	2/8	1/20	1/20	
Vibration resistance: NO/NC		According to EN 61373			
Shock resistance		According to EN 61373			
Power lost to the environment	without contact current	W	0.8	0.8	0.8
	with rated current	W	1.4	2.3	2.8

G

Contact specifications

Contact diagrams

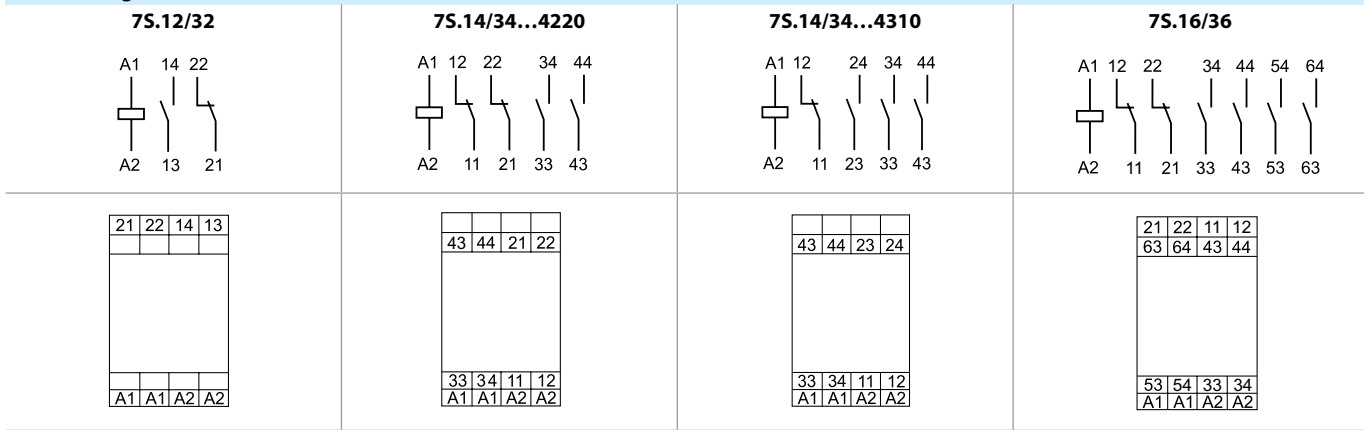

F 7S12 - Electrical life (AC) v contact current - 7S.12

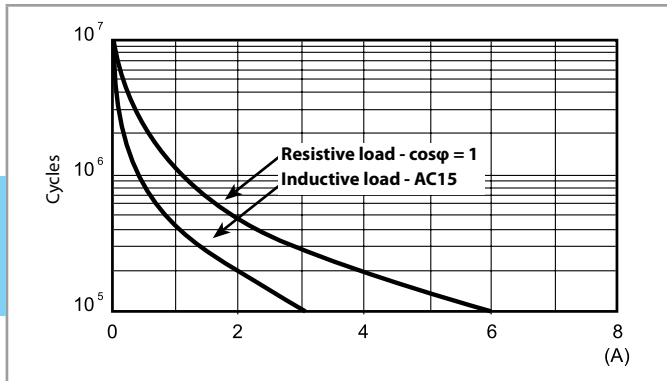

H 7S12* - Maximum DC breaking capacity - 7S.12

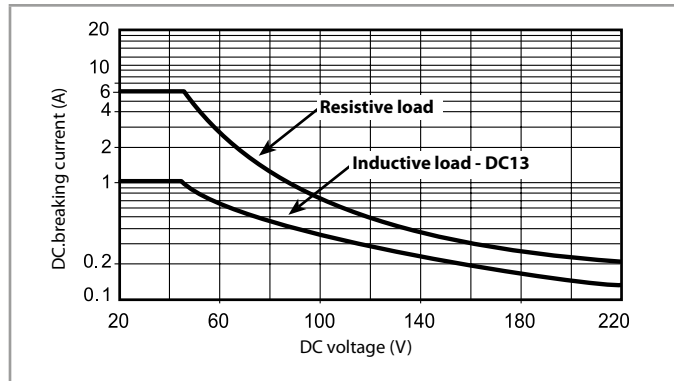

F 7S14 - Electrical life (AC) v contact current - 7S.14/34

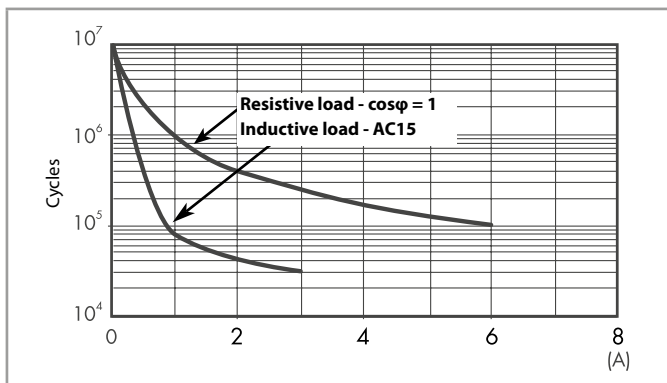

H 7S14* - Maximum DC breaking capacity - 7S.14/34

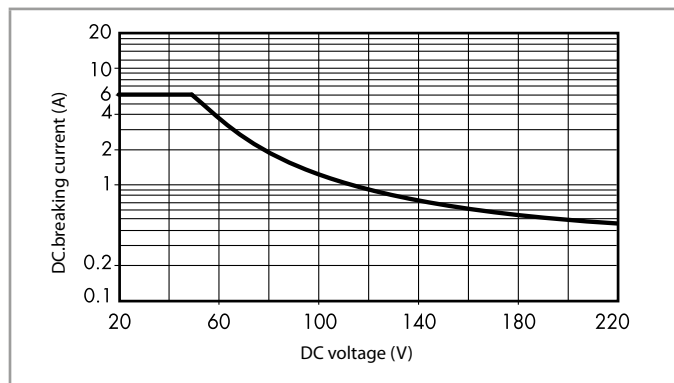

F 7S16 - Electrical life (AC) v contact current - 7S.16/36

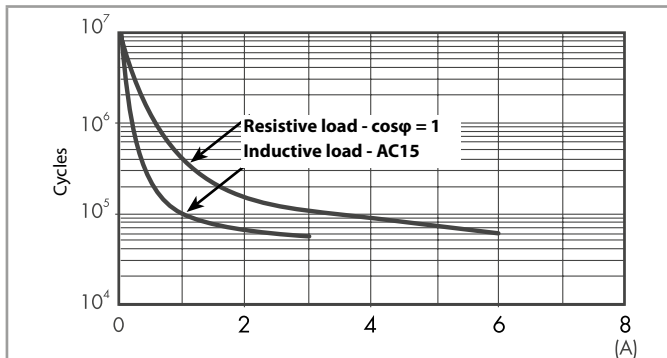

H 7S16* - Maximum DC breaking capacity - 7S.16/36

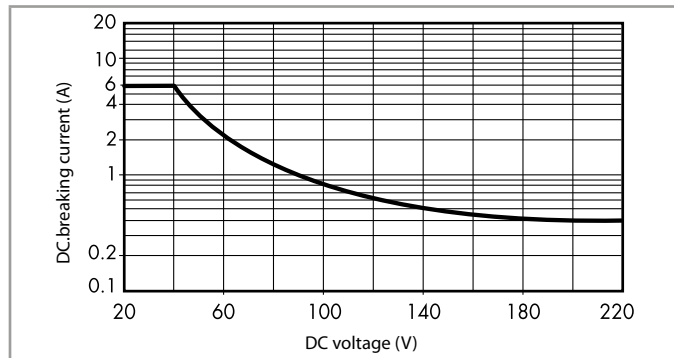

* When switching a load having voltage and current values under the curve, an electrical life of $\geq 100 \cdot 10^3$ can be expected.

Coil specifications

DC coil data - type 7S.12/32

Nominal voltage	Coil code	Operating range		Rated input current at U_N	Rated power at U_N
		U_{min}	U_{max}		
U_N		V	V	I_N	W
V		V	V	mA	W
24	9.024	16.8	30	38.2	0.9

AC coil data - type 7S.12/32

Nominal voltage	Coil code	Operating range		Rated input current at U_N	Rated power at U_N
		U_{min}	U_{max}		
U_N		V	V	I_N	VA/W
V		V	V	mA	VA/W
110...125	8.120	93	138	9.8	1.2/1.1
230...240	8.230	195	264	11.8	2.8/1.2

DC coil data - type 7S.14/34 / 7S.16/36

Nominal voltage	Coil code	Operating range		Rated input current at U_N	Rated power at U_N
		U_{min}	U_{max}		
U_N		V	V	I_N	W
V		V	V	mA	W
24	9.024	16.8	30	42.2	1
110	9.110	77	138	11.6	1.4

AC coil data - type 7S.14/34 / 7S.16/36

Nominal voltage	Coil code	Operating range		Rated input current at U_N	Rated power at U_N
		U_{min}	U_{max}		
U_N		V	V	I_N	VA/W
V		V	V	mA	VA/W
110...125	8.120	93	138	10.2	1.3/1.1
230...240	8.230	195	264	11.8	2.9/1.2

R 7S - DC coil operating range v ambient temperature - 7S.12/32 / 7S.14/34 / 7S.16/36

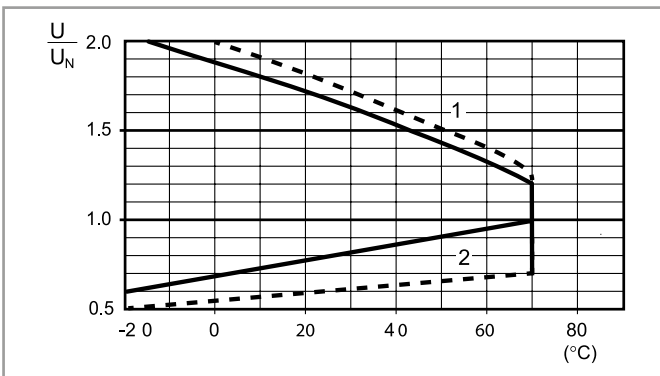

- 1 - Max. permitted coil voltage.
- 2 - Min. pick-up voltage with coil at ambient temperature.
- 24 and 110 V DC coils only (extended range)

R 7S - AC coil operating range v ambient temperature - 7S.12/32 / 7S.14/34 / 7S.16/36

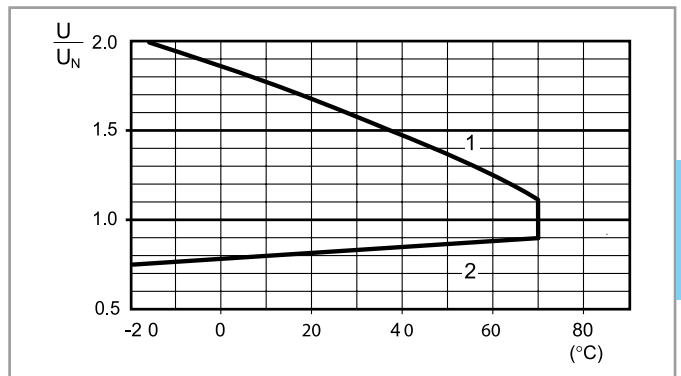

- 1 - Max. permitted coil voltage.
- 2 - Min. pick-up voltage with coil at ambient temperature.

Wiring diagrams

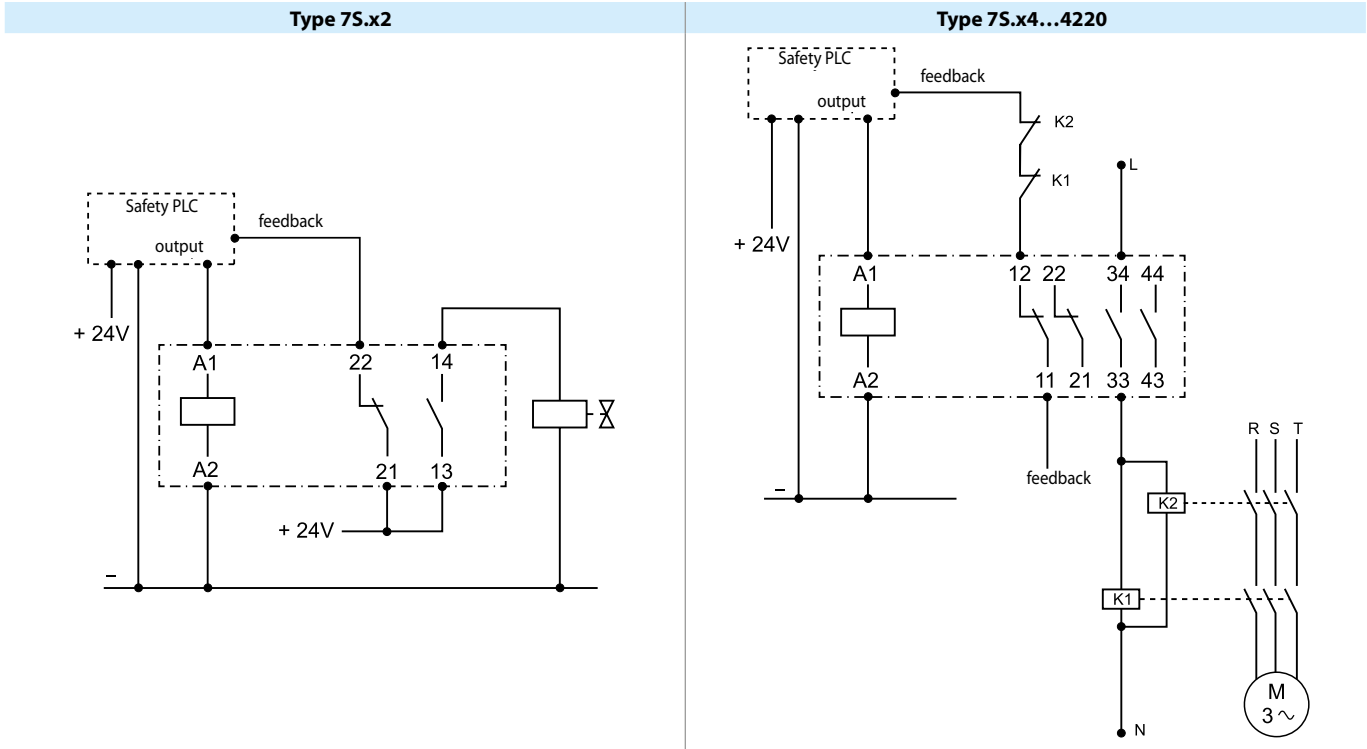

Outline drawings

Type 7S.xx
Screwless terminal

G

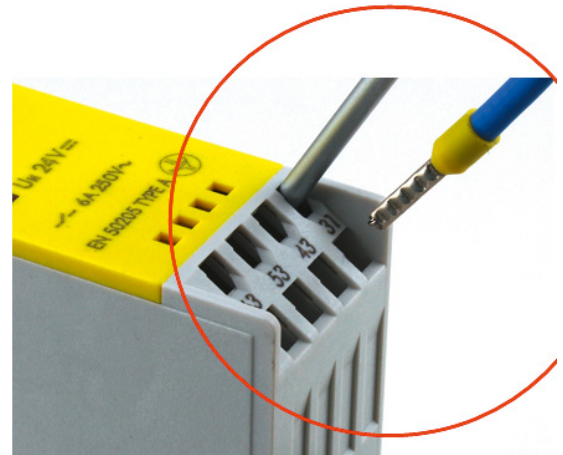
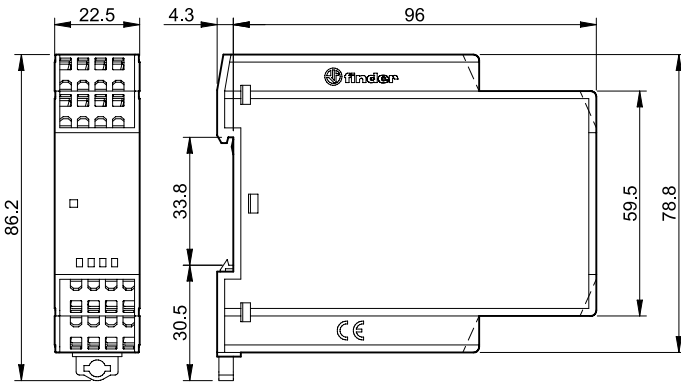

Accessories

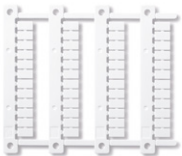

060.48

Sheet of marker tags, plastic, 48 tags, 6 x 12 mm, for CEMBRE thermal transfer printers

060.48