

# Relay actuators & Status indicating modules



Panels for  
electrical  
distribution





**Auto/Off/On output module 10 A**

- Auto/Off/On output module intended to permit the automatic control of pumps, blowers or motor groups. Or, in the case of installation, maintenance or failure, to permit the load equipment to be turned "Off" or turned "On"
- Ideal interface for PLC and electronic systems
- Only 11.2 mm wide
- 3 function selector switch:
  - Auto: works as a monostable relay (following A3 input)
  - Off: relay permanently OFF
  - On: relay permanently ON
- 24 V AC/DC supply and module input
- 35 mm rail (EN 60715) mounting

**Application examples:**

- control of pumps, blowers or motor groups
- primarily suited to Industrial control systems

**Wiring diagram**

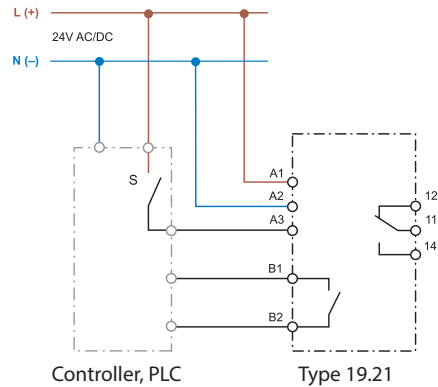

For outline drawing see page 9

**Contact specification**

Contact configuration		1 CO (SPDT)
Rated current/Maximum peak current	A	10/15
Rated voltage/Maximum switching voltage	V AC	250/400
Rated load AC1	VA	2500
Rated load AC15 (230 V AC)	VA	500
Single phase motor rating (230 V AC)	kW	0.44
Breaking capacity DC1 (24/110/220 V)	A	10/0.3/0.12
Minimum switching load	mW (V/mA)	300 (5/5)
Standard contact material		AgSnO <sub>2</sub>

**Feedback contact specification (terminals B1-B2)**

Contact configuration		1 NO (SPST-NO)
Maximum current	mA	300
Rated voltage	V AC/DC	24

**Supply & Input specification**

Nominal voltage (U <sub>N</sub> )	V AC (50/60 Hz)	24
	V DC	24
Rated power	VA (50 Hz)/W	0.6/0.4
Operating range	AC	(0.8...1.1)U <sub>N</sub>
	DC	(0.8...1.1)U <sub>N</sub>

**Technical data**

Ambient temperature range	°C	-20...+50
Protection category		IP 20

**Approvals (according to type)**

19.21.0.024.0000



- 1 CO output contact
- 11.2 mm wide
- Feedback contact

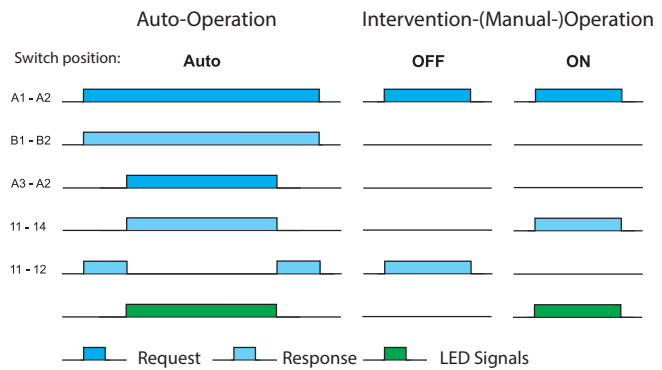

B1-B2 feedback to the controller signaling Auto-operation  
A3-A2 "Auto" signal from Controller

B

**Analogue override module - Auto/Hand (0...10)V**

- Analogue output module intended to provide, by the selection switch on the front panel, a (0...10)V output, automatically or by hand.
- With the selector switch in position "A" (Automatic) the (0...10)V signal is derived from the controller.
- In position "H" (Hand) the controller signal is ignored and the (0...10)V signal is derived directly from the potentiometer setting on the fascia of the module
- The level of the (0...10)V output signal is displayed by 3 green LEDs, set at > 25%, > 50% and > 75%.
- 24 V AC/DC supply
- 35 mm rail (EN 60715) mounting

**Application examples:**

- permits the direct control of proportional valves under exceptional circumstances or where the automatic controller has failed

**Wiring diagram**

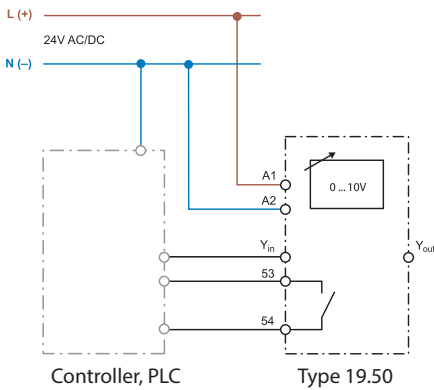

**19.50.0.024.0000**



- Analogue output (0...10)V, plus 1 feedback output contact
- 17.5 mm wide
- LED indicator

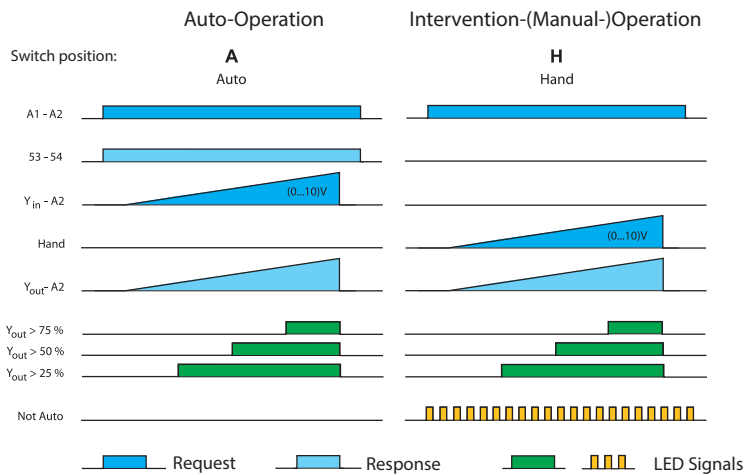

53-54 feedback to the controller signaling Auto-operation  
 $Y_{in}$ -A2 variable (0...10)V DC from the controller  
 Hand (0...10)V DC value set by the potentiometer

For outline drawing see page 9

**(0...10)V Signal specification (terminal  $Y_{in}$ )**

Input control signal	V DC	0...10 (I <sub>max</sub> 20 mA - short-circuit protected)
Green LED 25%		> 2.5 V
Green LED 50%		> 5 V
Green LED 75%		> 7.5 V

**Feedback output specification (terminals 53-54)**

Output configuration		1 NO (SPST-NO)
Maximum / Minimum current	mA	100/10
Rated voltage	V AC/DC	24

**Supply & Input specification**

Nominal voltage ( $U_N$ )	V AC (50/60 Hz)	24
	V DC	24
Rated power AC/DC	VA (50 Hz)/W	0.9/0.7
Operating range	AC	(0.8...1.1) $U_N$
	DC	(0.8...1.1) $U_N$

**Technical data**

Ambient temperature range	°C	-20...+50
Protection category		IP 20

**Approvals (according to type)**



**Power relay module 16 A**

- Suitable for Lamps load
- AgSnO<sub>2</sub> contacts for heavy duty, high inrush current loads
- DC supply (12 or 24 V)
- LED indicator
- Reinforced insulation between supply and contacts
- Cadmium Free contacts
- 35 mm rail (EN 60715) mounting

**Wiring diagram**

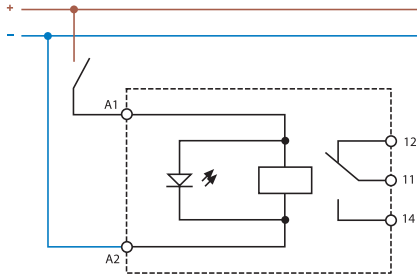

For outline drawing see page 9

**Contact specification**

Contact configuration		1 CO (SPDT)
Rated current/Maximum peak current	A	16/30 (120 A - 5 ms)
Rated voltage/ Maximum switching voltage	V AC	250/440
Rated load AC1	VA	4000
Rated load AC15 (230 V AC)	VA	750
Nominal lamp rating (230 V):		
incandescent/halogen W		2000
fluorescent tubes with electronic ballast W		1000
fluorescent tubes with electromagnetic ballast W		750
CFL W		400
230 V LED W		400
halogen or LED with electronic ballast W		400
halogen or LED with electromagnetic ballast W		800
Minimum switching load	mW	300 (5 V/ 5 mA)
Standard contact material		AgSnO <sub>2</sub>

**Coil specification**

Nominal voltage (U <sub>N</sub> )	VDC	12 - 24
Rated power DC	W	0.5
Operating range		(0.8 ... 1.1)U <sub>N</sub>

**Technical data**

Mechanical life AC/DC	cycles	10 · 10 <sup>6</sup>
Electrical life at rated load AC1	cycles	80 · 10 <sup>3</sup>
Operate/release time	ms	12/8
Ambient temperature range	°C	-20...+50
Protection category		IP 20

**Approvals** (according to type)



**19.91.9.0xx.4000**



- 1 Pole changeover contact
- 17.5 mm

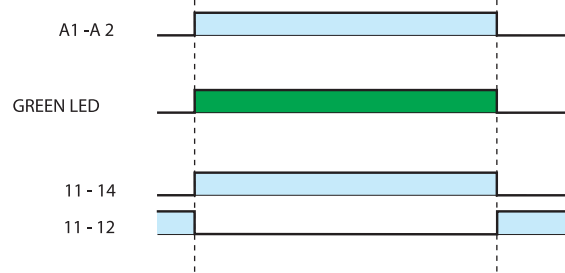

**Switching actuator with KNX technology - 16 A**

**Type 19.3K.9.030.4300**

- 6 relays for 3 roller shutters
- Logically interlocked outputs
- Slats management (3 different types)

**Type 19.6K.9.030.4300**

- Compact and powerful switching actuator with 6 relay outputs
- 6 output contacts rated 16 A 250 V AC, individually configurable NO or NC
- Time functions (ON, OFF, Blink, Staircase)
- Independent logic and analog functions for each output (AND, OR, XOR, THRESHOLD, WINDOW)
- LED status indicator for each output
- Scenario Management
- Output control area for manual control
- Supply voltage via KNX bus
- 35 mm rail (EN 60715) mounting

19.3K/19.6K  
Screw terminal

KNX terminal



For outline drawing see page 9

**Contact specification**

Contact configuration (via ETS)	V AC	NO - NC	NO - NC
Rated current/Maximum peak current	A	16/120 (5 ms)	16/120 (5 ms)
Rated voltage/ Maximum switching voltage	V	250/400	250/400
Rated load AC1	VA	4000	4000
Rated load AC15 (230 V AC)	VA	750	750
Single phase motor rating (230 V AC)	kW	0.55	0.55
Nominal lamp rating (230 V):			
incandescent/halogen W		2000	2000
fluorescent lamp with electronic ballast W		1000	1000
fluorescent lamp with electromagnetic ballast W		750	750
CFL W		400	400
LED 230 V W		400	400
halogen or LV LED with electronic ballast W		400	400
halogen or LV LED with electromagnetic ballast W		800	800
Standard contact material		AgSnO <sub>2</sub>	AgSnO <sub>2</sub>

**Supply specification**

Type of BUS		KNX	KNX
Supply voltage	VDC	30	30
Nominal consumption	mA	15	15

**Technical data**

Mechanical life	cycles	10 · 10 <sup>6</sup>	10 · 10 <sup>6</sup>
Electrical life at rated load AC1	cycles	100 · 10 <sup>3</sup>	100 · 10 <sup>3</sup>
Ambient temperature range	°C	-5...+45	-5...+45
Protection category		IP 20	IP 20

**Approvals (according to type)**



**NEW 19.3K.9.030.4300**



- Bistable relay ENEC approved (Maximum peak current up to 120 A)
- Suitable for up to 3 roller shutters
- Slats management

**19.6K.9.030.4300**



- Bistable relay ENEC approved (Maximum peak current up to 120 A)
- Suitable for lamp loads

### Ordering information

Example: 19 series Auto/Off/On override module, 1 CO (SPDT) 10 A contact, 24 V AC/DC supply.

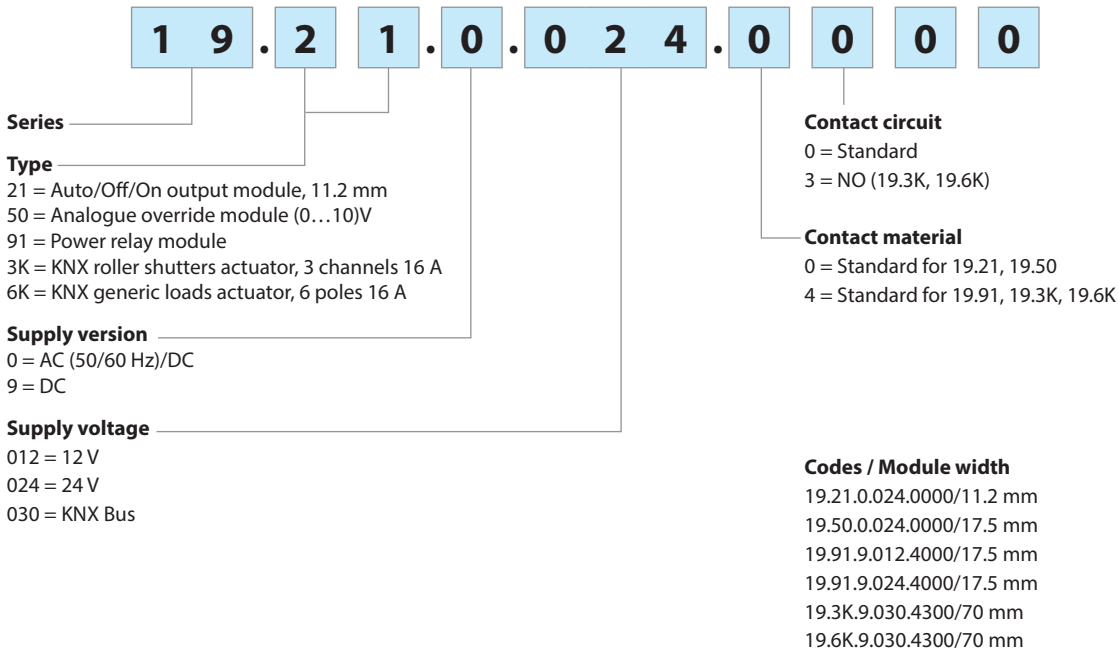

### Technical data

Insulation		19.21	19.50	19.91	
Dielectric strength (V AC)	between supply and contacts	3000	—	4000	
	between open contacts	1000	—	1000	
	between supply and feedback output	2000	1500	—	
EMC specifications					
Type of test		Reference standard	19.21/91	19.50	
Electrostatic discharge	contact discharge	EN 61000-4-2	4 kV		
	air discharge	EN 61000-4-2	8 kV		
Radiated electromagnetic field (80...1000 MHz)		EN 61000-4-3	30 V/m		
Fast transients (burst) (5-50 ns, 5 kHz)		EN 61000-4-4	4 kV		
Voltage pulses (1.2/50 µs)	common mode	EN 61000-4-5	2 kV	1 kV	
	on supply terminals	differential mode	EN 61000-4-5	1 kV	0.5 kV
Terminals		19.21/3K/6K		19.50/91	
Screw torque	Nm	0.5		0.8	
Max. wire size	mm <sup>2</sup>	solid cable	stranded cable	solid cable	stranded cable
		1 x 6 / 2 x 2.5	1 x 4 / 2 x 1.5	1 x 6 / 2 x 4	1 x 4 / 2 x 2.5
		AWG 1 x 10 / 2 x 14	1 x 12 / 2 x 16	1 x 10 / 2 x 12	1 x 12 / 2 x 14
Wire strip length	mm	7		9	

Wiring diagrams - Application examples

Type 19.21

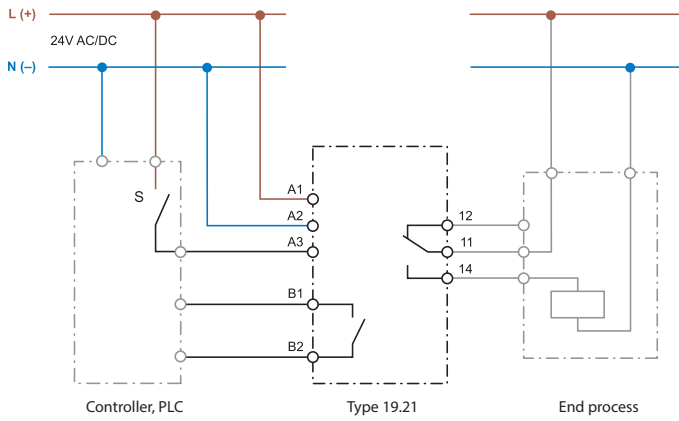

Type 19.50

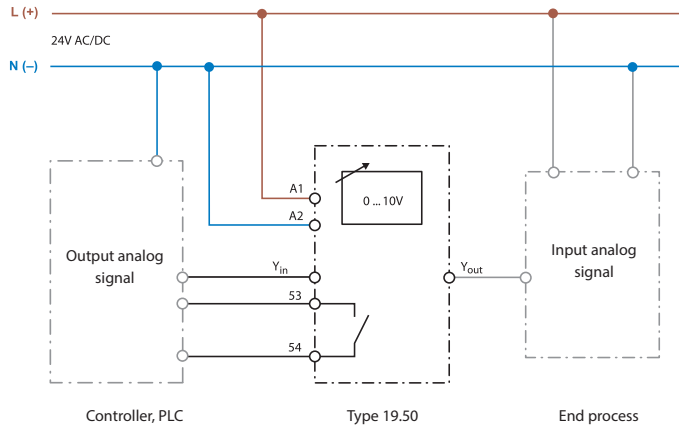

In selector position A (Automatic) the (0...10)V controller variable is transferred via  $Y_{in}$  - A2 and  $Y_{out}$  to the end process.  
In selector position H (Hand) the (0...10)V value set by the regulator is transferred via  $Y_{out}$  to the end process.

Type 19.3K

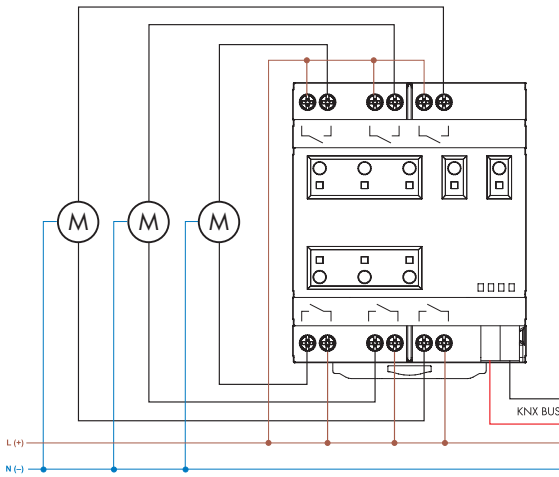

Type 19.6K

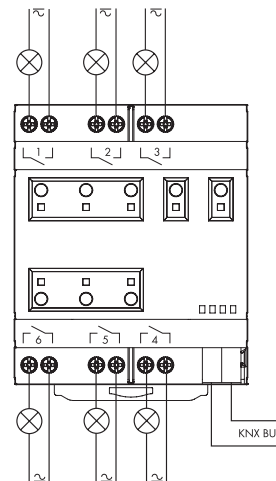



Outline drawings

Type 19.21  
Screw terminal

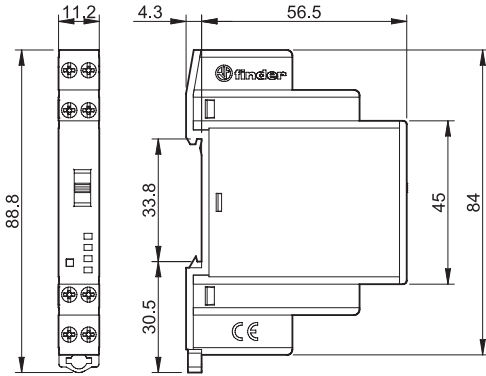

Type 19.50  
Screw terminal

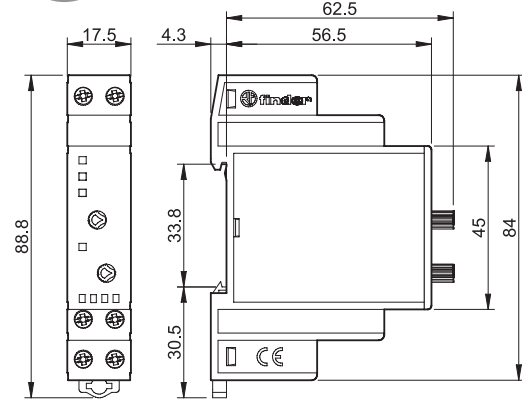

Type 19.91  
Screw terminal

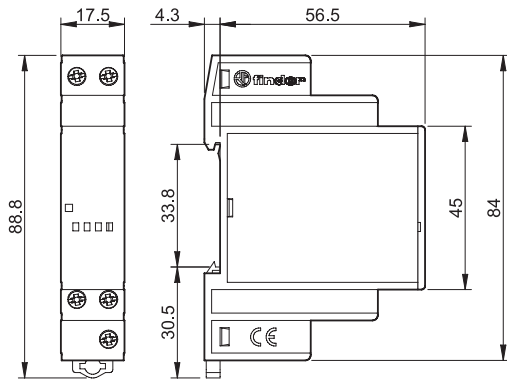

Type 19.3K/19.6K  
Screw terminal      KNX terminal

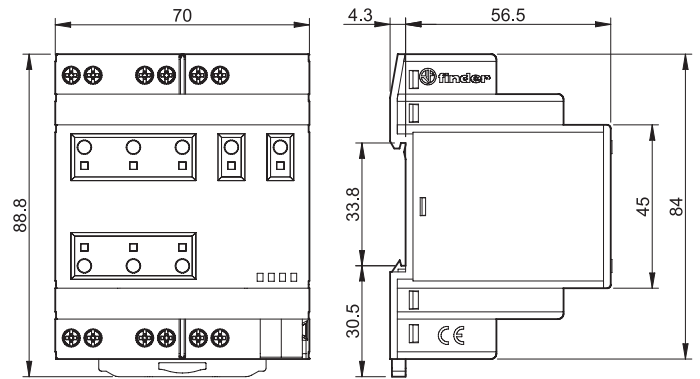

B

Accessories

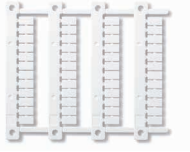

060.48

**Sheet of marker tags (CEMBRE Thermal transfer printers)** for 19.21/50/91/3K/6K types,  
(48 tags) 6 x 12 mm

060.48

B



019.01

**Identification tag**, for 19.50 types, plastic, 1 tag, 17 x 25.5 mm

019.01



020.01

**Adaptor for panel mounting**, for 19.21/50/91 types, plastic, 17.5 mm wide

020.01

## Application notes

### Intervention Modules

The demand for security apparatus, heating, air conditioning or efficient energy use in offices, hotels, and private homes or in industrial space is growing constantly, leading to the installation of increasingly complex electronic systems. But what happens if these systems malfunction and a qualified service technician will only be available in a few hours, or even days?

With the use of carefully installed intervention modules, a trained caretaker or security guard can be in a position to recognize interruptions in service, and by manual intervention perform the necessary override actions to maintain system operation until a repair can be effected.

### Digital Override control module

#### Auto-Off-On output module (Type 19.21)

Many processes or systems are automatically controlled by an electronic control system or by a Programmable Logic Controller.

In the event of an electronic system malfunction it is important, in order to avoid damage or downtime, to plan for the possibility of controlling the process manually. An Auto-Off-On Module can provide this, located between the output of the electronic system (Controller) and the process to be controlled (End Process) - bypassing the malfunctioning control unit in a planned way. For malfunctioning electronic systems, the process to be controlled can be manually switched On or Off, as needed, using the switch on the front of the unit. Under healthy functioning of the electronic system, the switch is left in the Auto position. In this configuration the process is controlled by the normal functioning of the electronic system and its output. It may be important to know (remotely) if the process is being controlled manually or automatically, in which case the feedback contact on the Auto-Off-On module 19.21 can provide this.

### Analogue Override control module

#### Analogue output module (0...10)V (Type 19.50)

This module can be installed where there is need to give a manually adjustable analog signal (0...10)V priority over an analog signal from a electronic control unit or PLC, or to override and replace a malfunctioning signal.

The Analogue override module provides, by the selection switch on the front panel, a (0...10)V output signal either generated automatically or by hand. With the selector switch in position "A" (Automatic) the (0...10)V signal at  $Y_{out-A2}$  is derived from the controller signal applied to terminals  $Y_{in-A2}$ . In position "H" (Hand) the controller signal is ignored and the (0...10)V signal is derived directly from the potentiometer setting on the module front panel.

Operation in switch position H is indicated by a blinking yellow LED, and by the opening of contact 51-52 – which could be used to report the override condition to the central control room.

The level of the (0...10)V output signal is displayed by 3 green LEDs, set at > 25%, > 50% and > 75%

