



CODESYS



8A.04

	8A.04.9.024.832C U _N (12...24) V DC + -15% Class 2 source I < 200 mA
	OUTPUT 4 NO (SPST) 10 A, 250 V AC1 4 A, 24 V DC1 1/2 HP 240 V AC 1/4 HP 120 V AC
	INPUT 8 digital/analog (0...10 V)
	STM32H747XI Dual ARM® Cortex® M7/M4 IC: 1x ARM® Cortex® -M7 core up to 480 MHz 1x ARM® Cortex® -M4 core up to 240 MHz
	USB Type C 10/100 Ethernet RS485 Wi-Fi + BLE
	Secure element integrated
	(-20...+50)°C
Open type, EN 60715 rail mounting Environmental Conditions: Extended Humidity 5-95 RH% Altitude 2000 m IP20	

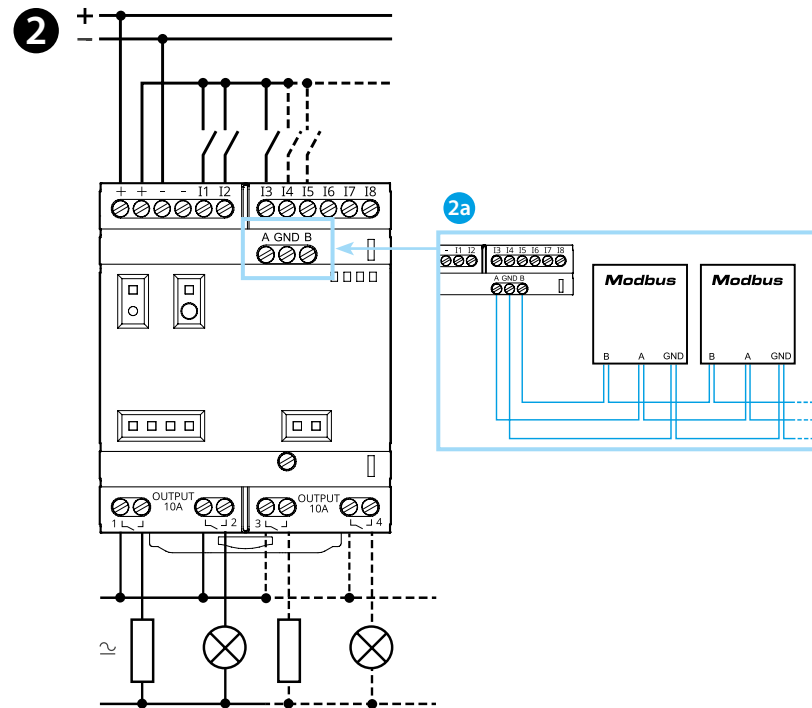
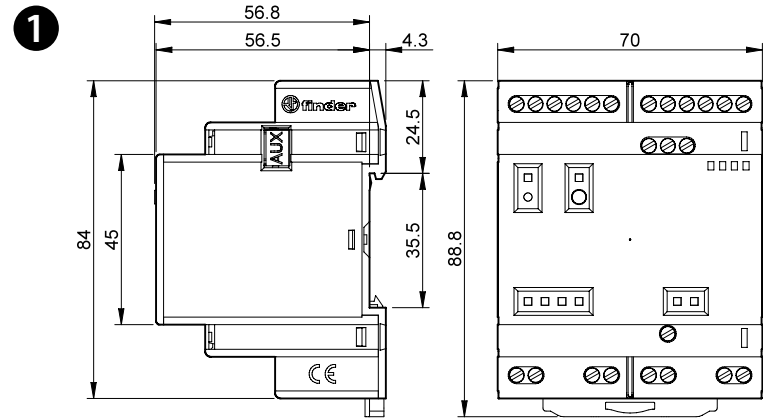
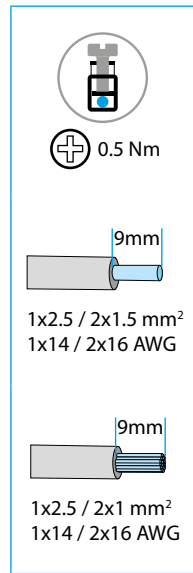

FCC and RED CAUTIONS (MODEL 8A.04.9.024.832C)

FCC
Any Changes or modifications not expressly approved by the party responsible for compliance could void the user's authority to operate the equipment. This device complies with part 15 of the FCC Rules. Operation is subject to the following two conditions: (1) This device may not cause harmful interference, and (2) this device must accept any interference received, including interference that may cause undesired operation.

FCC RF Radiation Exposure Statement:
- this Transmitter must not be co-located or operating in conjunction with any other antenna or transmitter
- this equipment complies with RF radiation exposure limits set forth for an uncontrolled environment
- this equipment should be installed and operated with minimum distance 20 cm between the radiator & your body

NOTE
This equipment has been tested and found to comply with the limits for a Class A digital device, pursuant to part 15 of the FCC Rules. These limits are designed to provide reasonable protection against harmful interference when the equipment is operated in a commercial environment. This equipment generates, uses, and can radiate radio frequency energy and, if not installed and used in accordance with the instruction manual, may cause harmful interference to radio communications. Operation of this equipment in a residential area is likely to cause harmful interference in which case the user will be required to correct the interference at his own expense.

RED
The product is in compliance with essential requirements and other relevant provisions of Directive 2014/53/EU. This product is allowed to be used in all EU member states.

Frequency bands	Maximum output power (EIRP)
2412 - 2472 MHz (2.4G WiFi)	5,42 dBm
2402 - 2480 MHz (BLE)	2,41 dBm
2402 - 2480 MHz (EDR)	-6,27 dBm

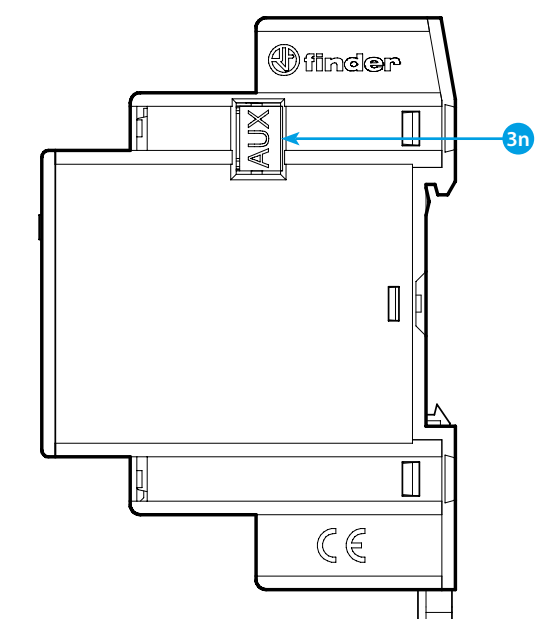
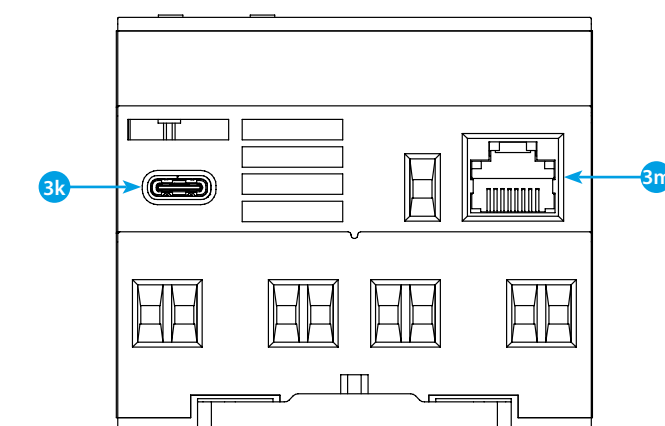
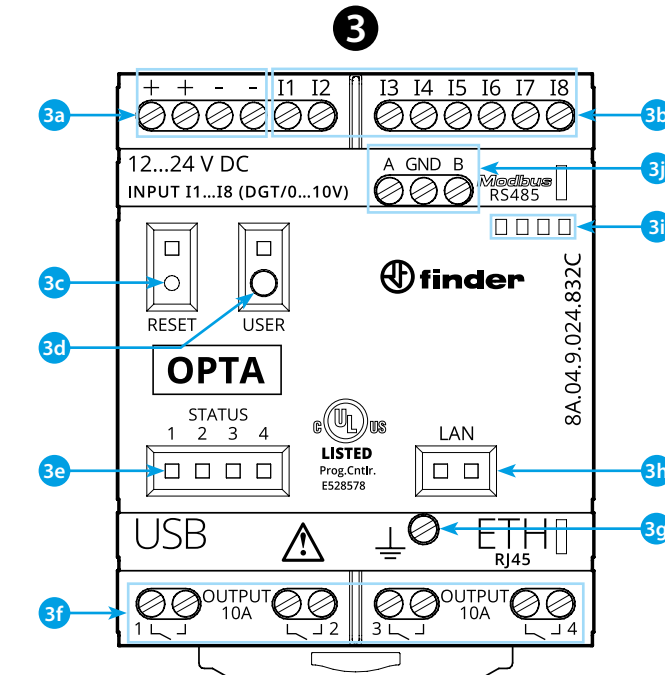

ESPAÑOL

8A.04.9.024.8320C Versión Codesys

- DIMENSIONES**
- ESQUEMA DE CONEXIONADO**
2a Conexión Modbus RTU
- VISTA FRONTAL**
3a Bornes de alimentación 12...24 V DC
3b Bornes I1...I8 de entrada digital/analógica (0...10 V) configurables vía IDE
3c Pulsador de RESET (Pulsar con herramienta puntiaguda aislada)
3d Botón programable por el usuario
3e LED de estado del contacto 1...4
3f Borne 1...4 de salida a relé, contacto NA (SPST) 10 A 250 V AC
3g Borne de tierra funcional (ETH)
3h LED de estado del puerto Ethernet
3i Ranura para etiqueta de identificación 060.48
3j Bornes de conexión MODBUS RS485
3k USB-C para programación y registro de datos
3m Puerto Ethernet
3n Puerto para comunicación y conexión de módulos auxiliares

INFORMACIÓN PARA COMENZAR: opta.findernet.com
Para poder programar su Finder OPTA Tipo 8A.04, deberá instalar el entorno de desarrollo CODESYS y el complemento Finder, ambos disponibles en el sitio web opta.findernet.com. Para conectar el Finder OPTA 8A.04 a su ordenador, necesitará un cable de datos USB-C. Este mismo cable proporciona energía al 8A.04, como lo indica el LED.

NOTA
Si el dispositivo se utiliza de una manera no especificada por el fabricante, la protección proporcionada por el dispositivo puede verse afectada.

