



CODESYS



8A.04

	8A.04.9.024.832C U _N (12...24) V DC + -15% Class 2 source I < 200 mA
OUTPUT 	4 NO (SPST) 10 A, 250 V AC1 4 A, 24 V DC1 1/2 HP 240 V AC 1/4 HP 120 V AC
INPUT 	8 digital/analog (0...10 V)
	STM32H747XI Dual ARM® Cortex® M7/M4 IC: 1x ARM® Cortex® -M7 core up to 480 MHz 1x ARM® Cortex® -M4 core up to 240 MHz
	USB Type C 10/100 Ethernet RS485 Wi-Fi + BLE
	Secure element integrated
	(-20...+50)°C
Open type, EN 60715 rail mounting Environmental Conditions: Extended Humidity 5-95 RH% Altitude 2000 m IP20	

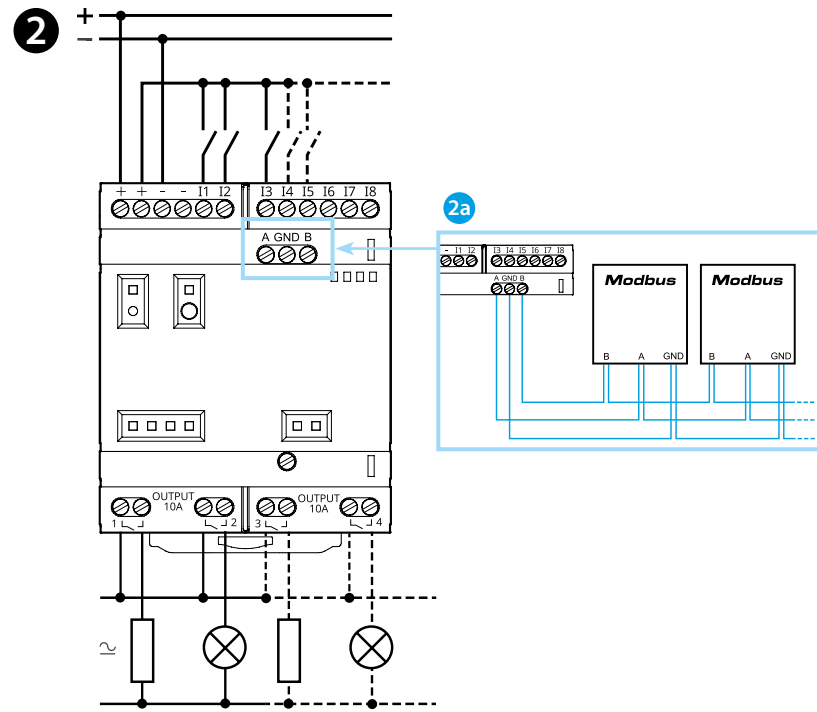
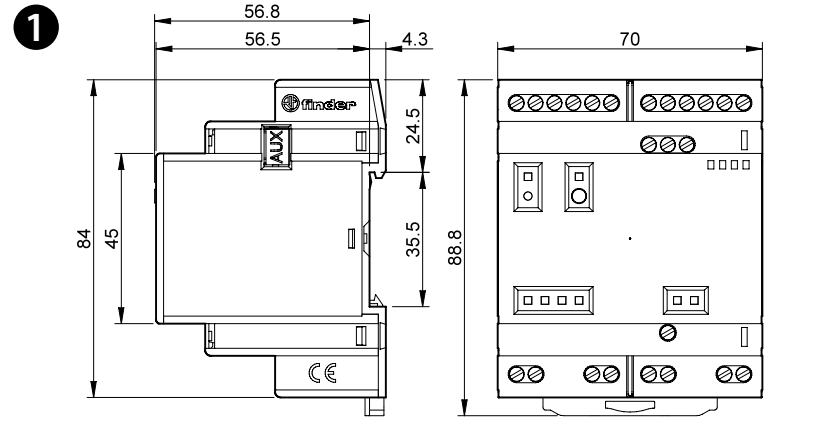
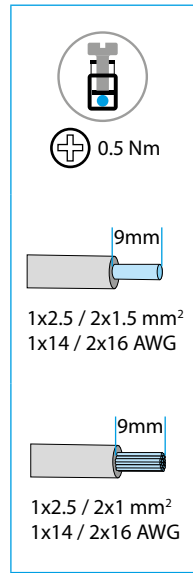

FCC and RED CAUTIONS (MODEL 8A.04.9.024.832C)

FCC
Any Changes or modifications not expressly approved by the party responsible for compliance could void the user's authority to operate the equipment. This device complies with part 15 of the FCC Rules. Operation is subject to the following two conditions: (1) This device may not cause harmful interference, and (2) this device must accept any interference received, including interference that may cause undesired operation.

FCC RF Radiation Exposure Statement:
- this Transmitter must not be co-located or operating in conjunction with any other antenna or transmitter
- this equipment complies with RF radiation exposure limits set forth for an uncontrolled environment
- this equipment should be installed and operated with minimum distance 20 cm between the radiator & your body

NOTE
This equipment has been tested and found to comply with the limits for a Class A digital device, pursuant to part 15 of the FCC Rules. These limits are designed to provide reasonable protection against harmful interference when the equipment is operated in a commercial environment. This equipment generates, uses, and can radiate radio frequency energy and, if not installed and used in accordance with the instruction manual, may cause harmful interference to radio communications. Operation of this equipment in a residential area is likely to cause harmful interference in which case the user will be required to correct the interference at his own expense.

RED
The product is in compliance with essential requirements and other relevant provisions of Directive 2014/53/EU. This product is allowed to be used in all EU member states.

Frequency bands	Maximum output power (EIRP)
2412 - 2472 MHz (2.4G WiFi)	5,42 dBm
2402 - 2480 MHz (BLE)	2,41 dBm
2402 - 2480 MHz (EDR)	-6,27 dBm

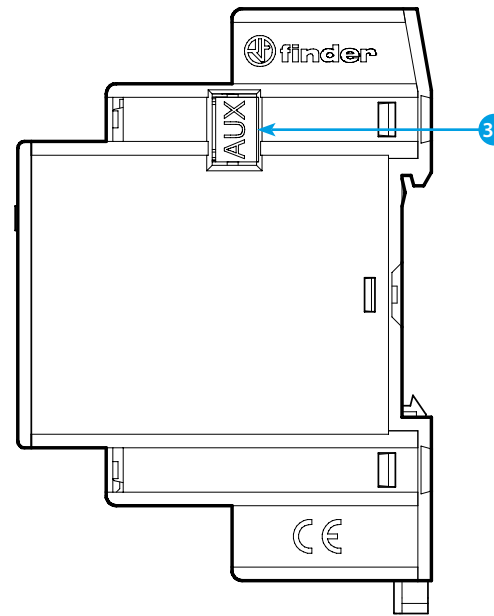
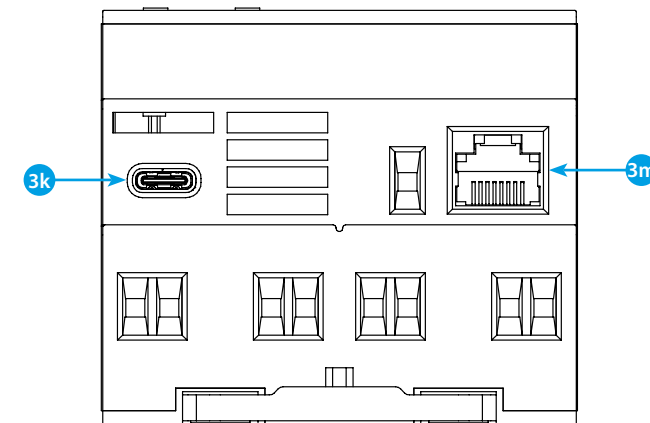
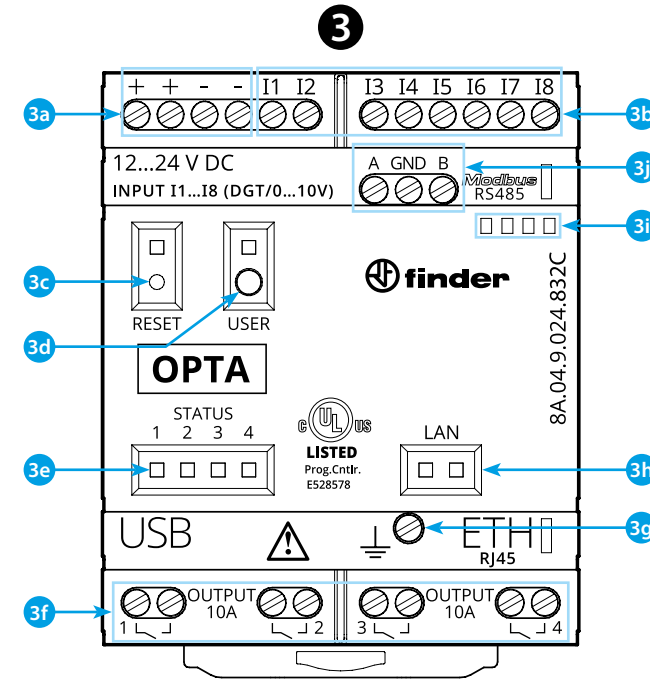

ENGLISH

8A.04.9.024.8320C Codesys Version

- DIMENSIONS**
- WIRING DIAGRAM**
2a Modbus RTU connection
- FRONT VIEW**
3a Power supply terminals 12...24 V DC
3b I1...I8 digital/analog input terminals (0...10 V) configurable via IDE
3c **Reset button** (Press with pointed tool isolated)
3d User programmable button
3e Contact status LED 1...4
3f Relay output terminals 1...4, NO contact (SPST) 10 A 250 V AC
3g Functional Earth
3h Ethernet port status LED
3i Label holder 060.48
3j Terminals for MODBUS RS485 connection
3k USB Type C for programming and data logging
3m Ethernet port
3n Port for communication and connection of auxiliary modules

GETTING STARTED opta.findernet.com
If you wish to program your Finder OPTA Type 8A.04 while offline, you will need to install the CODESYS development environment and the Finder plug-in, both available on the opta.findernet.com website. To connect the Finder OPTA Type 8A.04 to your computer, you will need a USB-C data cable. This also provides power to the Finder OPTA Type 8A.04, as indicated by the LED.

NOTE
If the equipment is used in a manner not specified by the manufacturer, the protection provided by the equipment may be impaired.

