

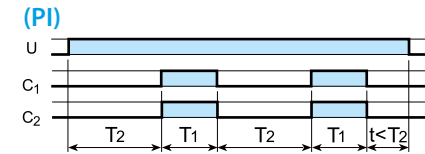

88.92

Utility Model - IB8892001 - 11/24 - Finder S.p.A. con unico socio - 10040 ALMESE (TO) - ITALY

	88.92.0.240.000X U _N (12...240)V AC (50/60 Hz) / DC U _{min} 10.8 V AC / DC U _{max} 264.5 V AC / DC P 2.5 VA (230 V) / 1.5 W (24 V)
	2 CO (DPDT) 8 A 250 V AC AC1 2000 VA AC15 (230 V AC) 400 VA (M) (230 V AC) 0.3 kW DC1(24/110/220)V (8/0.3/0.12)A
	(-10...+55)°C
IP40	

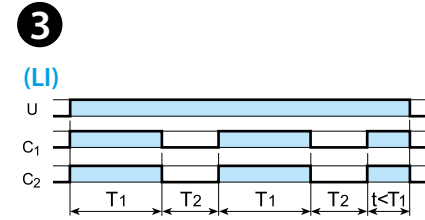
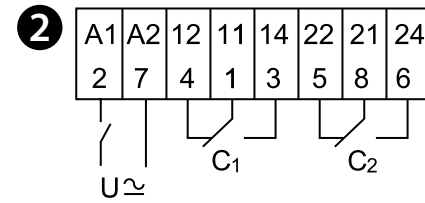
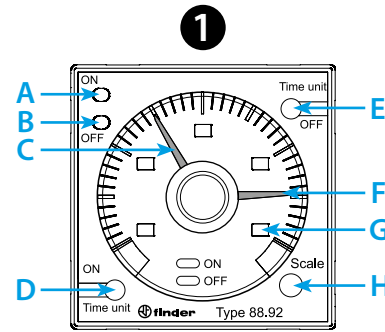
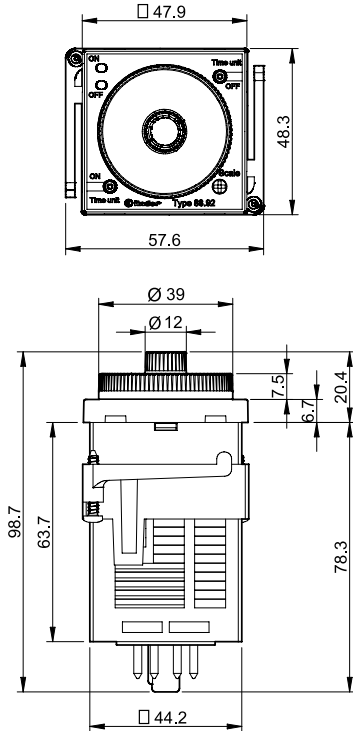

LED A (ON)	LED B (OFF)	U _N		
-	-	-	11 - 14 21 - 24	11 - 12 21 - 22
	-	✓	11 - 12 21 - 22	11 - 14 21 - 24
-		✓	11 - 14 21 - 24	11 - 12 21 - 22

H	D - E					
	s	10 s	min	10 min	h	10 h
1.2	1.2 s	12 s	1.2 min	12 min	1.2 h	12 h
3	3 s	30 s	3 min	30 min	3 h	30 h
12	12 s	120 s	12 min	120 min	12 h	120 h
30	30 s	300 s	30 min	300 min	30 h	300 h

ENGLISH

88.92
FRONT PANEL OR SOCKET MOUNT ASYMMETRICAL FLASHER

- FRONT VIEW**
 - A Red LED: pulse ON (T1)
 - B Green LED: pulse OFF (T2)
 - C Red timing regulator: T1 time setting
 - D Unit of time selector ON (T1): (s-10s - m-10min - h-10h) (*)
 - E Unit of time selector OFF (T2): (s-10s - m-10min - h-10h) (*)
 - F Green timing regulator: T2 time setting
 - G Time scale selected
 - H Time scale selector
- WIRING DIAGRAM**
- FUNCTIONS**
 - LI Asymmetrical flasher (starting pulse ON) (88.92.0.240.0001)
 - PI Asymmetrical flasher (starting pulse OFF) (88.92.0.240.0000)

NOTE

- The time scales settings (D-E-H) must be set before energising the timer
- Specified time range: (25 ms...300 h)
- Recovery time: 200 ms
- Setting accuracy full range: ± 1%
- (*) s (seconds), s 10 (seconds x10), m (minutes), m 10 (minutes x10), h (hours), h 10 (hours x10)