

Relay interface modules 0.1 - 2 - 6 A - ATEX - HazLoc



Common features

- Space saving 6.2 mm wide
- Connections for 16-way jumper link
- Integral coil indication and protection circuit
- Secure retention and easy ejection by plastic clip
- Dual screw head (blade+cross) terminals and Push-in terminals versions
- 35 mm rail mounting (EN 60715)

EMR
Electromechanical Relays

- 1 CO 6 A/250 V AC
- High switching capability

SSR
Solid State Relays

- 1 solid state output (options 0.1 A/48 V DC, 6 A/24 V DC, 2 A/240 V AC)
- Silent, high speed switching, long electrical life

MasterBASIC

- For general use in any type of system
- **EMR: 6 to 24 and 125 V AC/DC, 230 V AC supply**
- **SSR: 6 to 24 V DC, 125 V AC/DC, 230 V AC supply**
- **Multi-voltage EMR or SSR, 24...240 V AC/DC supply**
- Box clamp and Push-in terminal

39.11/39.01

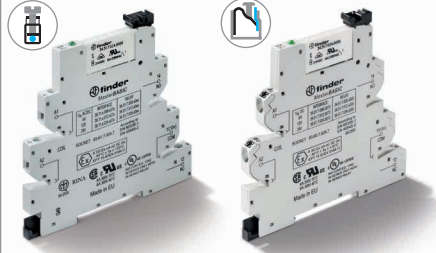

Page 5

39.10/39.00

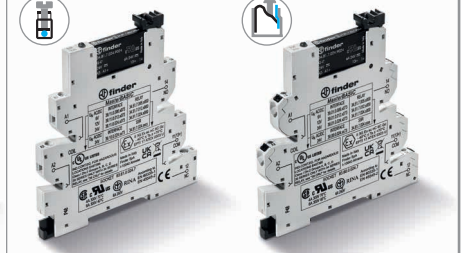

Page 6

MasterTIMER

- Timer adjustment via top mounted rotary knob accessible after assembly
- Control signal terminal
- DIP-switch for selection of 4 time scales and 8 functions
- **EMR and SSR: 12 to 24 V AC/DC supply**
- Box clamp and Push-in terminal

39.81/39.91

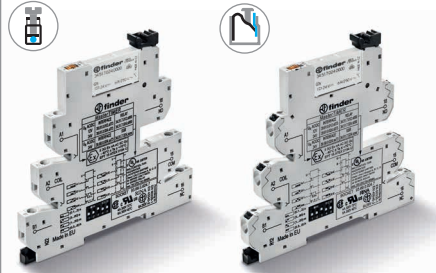

Page 7

39.80/39.90

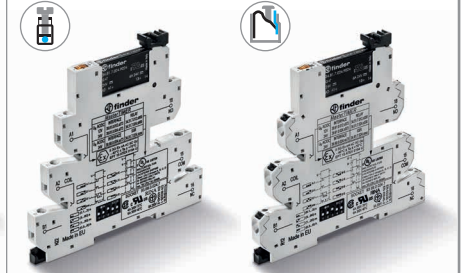

Page 8

MasterBASIC

39.11 - 39.10 - 39.01 - 39.00

- For general interface use in any type of system and application.
- Can be used for input interface applications between auxiliary contacts, sensors etc. and controllers, PLC's or motors. Or for output interface between PLC's controllers and relays, solenoids etc.

MasterTIMER

39.81 - 39.80 - 39.91 - 39.90

- Slim and Multifunction Timed Interface modules.

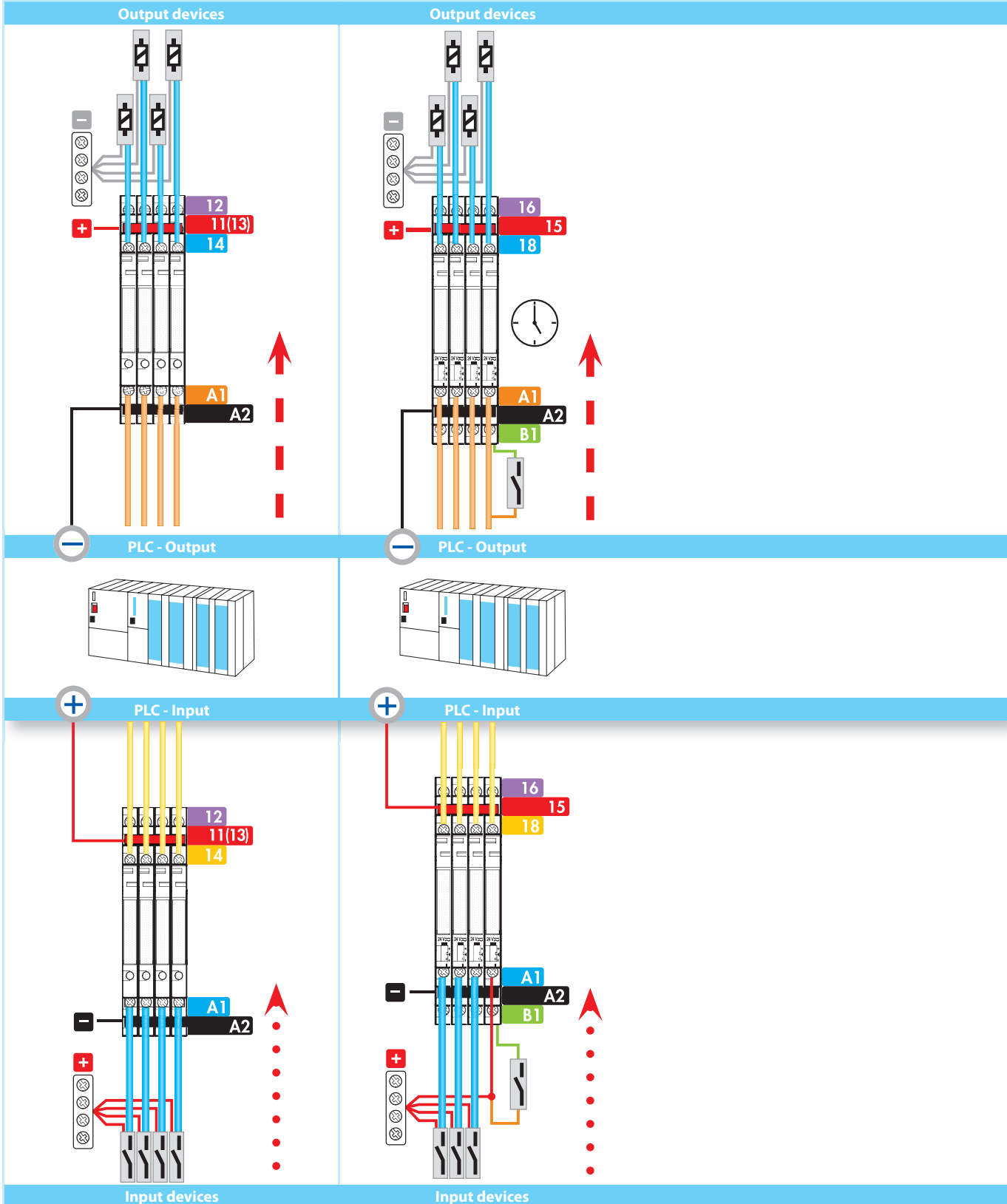

MasterBASIC - EMR ATEX

1 Pole interface module, 6.2 mm wide, ideal for PLC and electronic systems

ATEX compliant (Ex ec nC)

HazLoc Class I Div. 2 Group A, B, C, D - T6

- Electromechanical relay
- AC and AC/DC Version
- Box clamp and Push-in terminal
- UL Listed
- Cadmium free contacts
- Complies with:
 - EN 60079-0: 2012 and EN 60079-15:2010
- Common connection possible with optional jumper links (terminals A1, A2 and 11) and multipole connector *MasterADAPTER*
- 35 mm rail (EN 60715) mounting

39.11/39.01



- 1 CO 6 A
- Box clamp and push-in terminal
- 35 mm rail (EN 60715) mounting
- ATEX compliant

39.11
Box clamp



39.01
Push-in terminal



For outline drawing see page 18

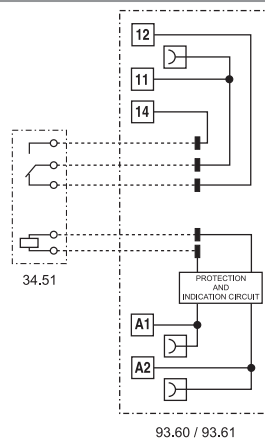

Contact specification

Contact configuration		1 CO (SPDT)
Rated current/ Maximum peak current	A	6/10
Rated voltage/ Maximum switching voltage	V AC	250/400
Rated load AC1	VA	1500
Rated load AC15 (230 V AC)	VA	300
Single phase motor rating (230 V AC)	kW	0.185
Breaking capacity DC1: 24/110/220 V	A	6/0.2/0.12
Minimum switching load	mW (V/mA)	500 (12/10)
Standard contact material		AgNi

Coil specification

Nominal voltage (U_N)	V AC/DC	6 - 12 - 24 - 110...125 - 24...240
	V AC (50/60 Hz)	230...240
Rated power AC/DC	VA (50 Hz)/W	See page 13
Operating range		(0.8...1.1) U_N
Holding voltage		0.6 U_N
Must drop-out voltage		0.1 U_N

Technical data

Mechanical life AC/DC	cycles	10 · 10 ⁶
Electrical life at rated load AC1	cycles	60 · 10 ³
Operate/release time	ms	5/6
Insulation between coil and contacts (1.2/50 μs)	kV	6 (8 mm)
Dielectric strength between open contacts	V AC	1000
Ambient temperature range	°C	-40...+70
Protection category		IP 20

Approvals relay (according to type)





MasterTIMER - EMR - Ex

Slim timed interface module, 6.2 mm wide, ideal for space-saving timing solutions in panels

- Timer adjustment via top mounted rotary knob, accessible after assembly
- Control signal terminal
- DIP-switch for selection of 4 time scales and 8 functions
- Common connection possible with optional jumper links (terminals A1, A2 and 15)
- **ATEX** compliant (Ex ec nC)
- **HazLoc** Class I Div. 2 Group A, B, C, D - T6

39.81/39.91

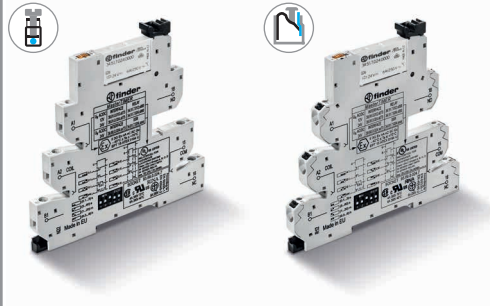

- 6 A electromechanical relay
- 12 - 24 V AC/DC supply
- Box clamp and push-in terminal
- 35 mm rail (EN 60715) mounting

39.81
Box clamp



39.91
Push-in terminal



* See L39 derating diagram at page 12

For outline drawing see page 18

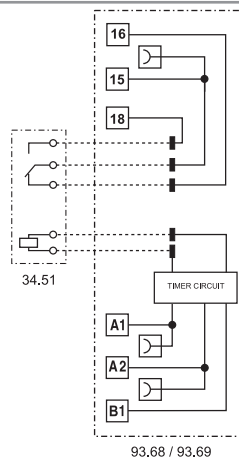

- AI:** On-delay
- DI:** Interval
- GI:** Pulse (0.5 s) delayed
- SW:** Symmetrical flasher (starting pulse on)
- BE:** Off-delay with control signal
- CE:** On- and off-delay with control signal
- DE:** Interval with control signal on
- EE:** Interval with control signal off

Contact specification

Contact configuration		1 CO (SPDT)
Rated current/ Maximum peak current	A	6/10
Rated voltage/ Maximum switching voltage	V AC	250/400
Rated load AC1	VA	1500
Rated load AC15 (230 V AC)	VA	300
Single phase motor rating (230 V AC)	kW	0.185
Breaking capacity DC1: 24/110/220 V	A	6/0.2/0.12
Minimum switching load	mW (V/mA)	500 (12/10)
Standard contact material		AgNi

Supply specification

Nominal voltage (U _N)	V AC/DC	12 - 24
Rated power AC/DC	VA (50 Hz)/W	See page 13
Operating range		(0.8...1.1)U _N
Holding voltage		0.6 U _N
Must drop-out voltage		0.1 U _N

Technical data

Specified time range		(0.1...3)s, (3...60)s, (1...20)min, (0.3...6)h
Repeatability	%	± 1
Recovery time	ms	≤ 50
Minimum control impulse	ms	50
Setting accuracy - full range	%	5
Electrical life at rated load AC1	cycles	60 · 10 ³
Ambient temperature range*	°C	-20...+50
Protection category		IP 20

Approvals relay (according to type)



MasterBASIC - SSR - HazLoc

1 Pole interface module, 6.2 mm wide, ideal for PLC and electronic systems

- Common connection possible with optional jumper links (terminals A1, A2 and 13+)
- HazLoc Class I Div. 2 Group A, B, C, D - T5 - T6

39.10/39.00

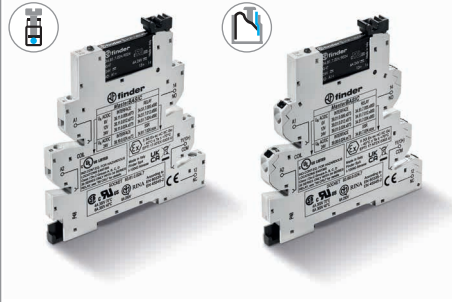

- 0.1, 2 or 6 A solid state relay
- 6 to 24 and 125 V AC/DC and 230 V AC supply
- Box clamp and push-in terminal
- 35 mm rail (EN 60715) mounting

39.10
Box clamp



39.00
Push-in terminal

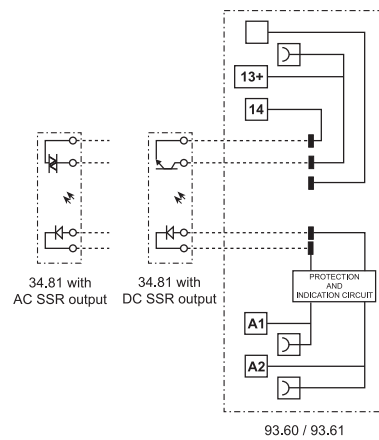

* See L39-1 and L39-2 derating diagram at page 14

For outline drawing see page 18

Output specification (SSR)		39.x0.x.xxx.9073	39.x0.x.xxx.7073	39.x0.x.xxx.8273
Contact configuration		1 NO (SPST-NO)		
Rated current/ Maximum peak current (10 ms)	A	6/50	0.1/0.5	2/80
Rated voltage/ Maximum blocking voltage	V	24/33 DC	48/53 DC	240/— AC
Switching voltage range	V	(1.5...33) DC	(1.5...53) DC	(12...275) AC
Repetitive peak off-state voltage	V _{pk}	—	—	800
Minimum switching current	mA	1	0.05	35
Max. "OFF-state" leakage current	mA	0.001	0.001	1.5
Max. "ON-state" voltage drop	V	0.4	1	1.6
Supply specification				
Nominal voltage (U _N)	V AC/DC	110...125		
	V AC (50/60 Hz)	220...240		
	V DC	6 - 12 - 24		
Rated power	VA (50 Hz)/W	See page 15		
Operating range		(0.8...1.1)U _N		
Must drop-out voltage		0.1 U _N		
Technical data				
Operate/release time	ms	0.2/0.6	0.04/0.6	12/12
Dielectric strength between input/output	V AC	3000		
Ambient temperature range*	°C	-20...+70		
Protection category		IP 20		
Approvals relay (according to type)				

MasterTIMER - SSR - Hazloc

Slim timed interface module, 6.2 mm wide, ideal for space-saving timing solutions in panels

- Timer adjustment via top mounted rotary knob; accessible after assembly
- Start terminal
- DIP-switch for selection of 4 time scales and 8 functions
- Common connection possible with optional jumper links (terminals A1, A2 and 15+)
- **HazLoc** Class I Div. 2 Group A, B, C, D - T5 - T6

39.80/39.90

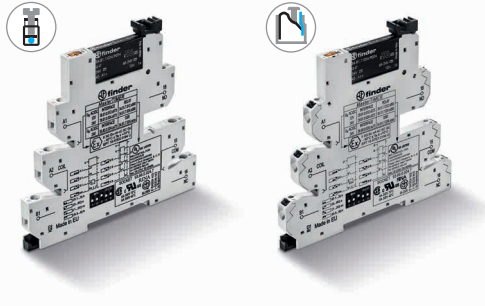

- 0.1, 2 or 6 A solid state relay
- 12 - 24 V AC/DC supply
- Box clamp and push-in terminal
- 35 mm rail (EN 60715) mounting

39.80
Box clamp



39.90
Push-in terminal

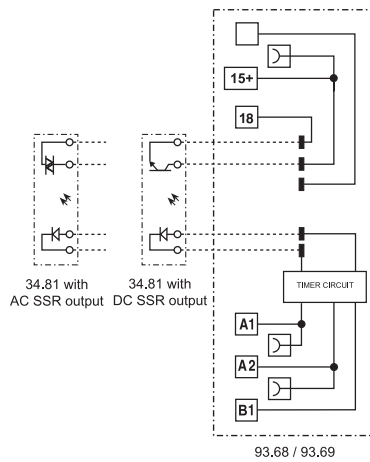

- AI:** On-delay
- DI:** Interval
- GI:** Pulse (0.5 s) delayed
- SW:** Symmetrical flasher (starting pulse on)
- BE:** Off-delay with control signal
- CE:** On- and off-delay with control signal
- DE:** Interval with control signal on
- EE:** Interval with control signal off

* See L39-1 and L39-2 derating diagram at page 14

For outline drawing see page 18

Output specification (SSR)		39.x0.x.xxx.9073	39.x0.x.xxx.7073	39.x0.x.xxx.8273
Contact configuration		1 NO (SPST-NO)		
Rated current/ Maximum peak current (10 ms)	A	6/50	0.1/0.5	2/80
Rated voltage/ Maximum blocking voltage	V	24/33 DC	48/53 DC	240/— AC
Switching voltage range	V	(1.5...33) DC	(1.5...53) DC	(12...275) AC
Repetitive peak off-state voltage	V _{pk}	—	—	800
Minimum switching current	mA	1	0.05	35
Max. "OFF-state" leakage current	mA	0.001	0.001	1.5
Max. "ON-state" voltage drop	V	0.4	1	1.6
Supply specification				
Nominal voltage (U _N)	V AC/DC	12 - 24		
Rated power	VA (50 Hz)/W	See page 15		
Operating range		(0.8...1.1)U _N		
Holding voltage		0.6 U _N		
Must drop-out voltage		0.1 U _N		
Technical data				
Specified time range		(0.1...3)s, (3...60)s, (1...20)min, (0.3...6)h		
Repeatability	%	± 1		
Recovery time	ms	≤ 50		
Minimum control impulse	ms	50		
Setting accuracy – full range	%	5		
Ambient temperature range*	°C	-20...+50		
Protection category		IP 20		
Approvals relay (according to type)				

Technical data

Insulation according to EN 61810-1			
Nominal voltage of supply system	V AC	230/400	
Rated insulation voltage	V AC	250	400
Pollution degree		3	2
Insulation between coil and contact set			
Type of Insulation		Reinforced	
Overvoltage category		III	
Rated impulse voltage	kV (1.2/50) μ s	6	
Dielectric strength	V AC	4000	
Insulation between open contacts (EMR)			
Type of disconnection		Micro-disconnection	
Dielectric strength	V AC/kV (1.2/50) μ s	1000/1.5	

Conducted disturbance immunity		$U_N \leq 60 V$	$U_N = 125 V$	$U_N = 230 V$
Fast transients (burst 5/50 ns, 5 kHz) according to EN 61000-4-4 at supply terminals	kV	4	4	4
Voltage pulses (surge 1.2/50 μ s) according to EN 61000-4-5 at supply terminals (differential mode)	kV	0.8	2	4

Other data				
Bounce time (EMR): NO/NC	ms	1/6		
Vibration resistance (EMR, 10...55 Hz): NO/NC	g	10/15		
Power lost to the environment	without contact current	W	0.2 (24 V) - 0.4 (230 V)	
	with rated current	W	0.6 (24 V) - 0.9 (230 V)	

Terminals			
		Box clamp	Push-in terminal
Wire strip length	mm	10	8
 Screw torque	Nm	0.5	—
		Solid and stranded cable	Solid and stranded cable
Min. wire size	mm ²	1 x 0.5	1 x 0.5
	AWG	1 x 21	1 x 21
Max. wire size	mm ²	1 x 2.5	1 x 2.5
	AWG	1 x 14	1 x 14

Ordering information ATEX - HazLoc versions

Example: 39 series, box clamp interface module, electromechanical relay output, 1 CO 6 A, 24 V AC/DC, ATEX - HazLoc version.

<p>Series ————</p> <p>Type ————</p> <p>0 = Push-in terminals 35 mm rail (EN 60715) mounting</p> <p>1 = Box clamp 35 mm rail (EN 60715) mounting</p> <p>8 = TIMER multifunction, box clamp</p> <p>9 = TIMER multifunction, push-in terminal</p> <p>No. of poles ————</p> <p>0 = 1 NO (only SSR)</p> <p>1 = 1 CO, 6 A</p> <p>Coil version ————</p> <p>0 = AC/DC</p> <p>8 = AC (50/60 Hz)</p> <p>Coil voltage ————</p> <p>See coil specifications</p>	<p style="margin-left: 100px;">A B C D</p> <p>3 9 . 1 1 . 0 . 0 2 4 . 0 0 7 3</p>	<p>A - B: Contact material - circuit</p> <p>00 = EMR AgNi contact CO (nPDT) Up to 6 A 250 V AC ATEX and Hazloc compliant</p> <p>50 = EMR AgNi + Au contact CO (nPDT) Up to 6 A 250 V AC ATEX and Hazloc compliant</p> <p>70 = SSR NO (SPST-NO) Up to 0.1 A - 48 V DC HazLoc compliant</p> <p>82 = SSR NO (SPST-NO) Up to 0.75 A - 277 V AC HazLoc compliant</p> <p>90 = SSR NO (SPST-NO) Up to 5 A - 24 V DC HazLoc compliant</p>	<p>C - D: Option</p> <p>73 = ATEX (Ex ec nC) and HazLoc Class I Div. 2 interface with EMR relay, or HazLoc Class I Div. 2 interface with SSR relay</p>
---	---	--	---

ATEX - Electrical characteristics

Max current @ 70 °C	Single piece mount	> 8 piece mount
Type 39.11/01	A 6	5
Type 39.11/01 (110...125)V AC/DC only	A 6	4
Terminals	Box clamp	Push-in Terminals
Wire strip length	mm 10	8
Screw torque	Nm 0.5	—
Min. wire size	solid and stranded cable	solid and stranded cable
	mm ² 0.5	0.5
	AWG 21	21
Max. wire size	solid and stranded cable	solid and stranded cable
	mm ² 1 x 2.5	1 x 2.5
	AWG 1 x 14	1 x 14

Markings - ATEX versions - ATEX, II 3G Ex ec nC IIC Gc

MARKING	
	Specific marking of explosion protection
II	Component for surface plant (different from mines)
3	Category 3: normal level of protection
GAS	G Explosive atmosphere due to presence of combustible gas vapour or mist
	Ex ec Increased safety
	Ex nC Sealed device (type of protection for category 3G)
	IIC Gas group
	Gc Equipment Protection Level
-40 °C ≤ Ta ≤ +70 °C Ambient temperature	
EPTI 17 ATEX 0303 U EPTI: laboratory which issues the CE type certificate 17: year of issue of certificate 0303: number of CE type certificate U: ATEX component	

Markings - Hazardous Location Class I Div. 2 Groups A, B, C, D - T5 - T6 and other data

HazLoc Class I Div. 2 Group A, B, C, D - T5 - T6		Meaning
Class I		Areas in which flammable gases and vapours may be present
Div. 2		Low probability to find ignitable concentration of hazards because are typically present in containers or closed systems from which can escape through their accidental rupture or breakdown
Group A, B, C, D		Kind of combustible, flammable gases and vapours can be in the atmosphere
Permissible Surface temperature		
T5	100 °C	212 °F
T6	85 °C	185 °F

Interface Code	Temperature code @ 40°C	40 °C		Temperature code @ 70 °C	70 °C	
		Current	Voltage		Current	Voltage
39.11.0.024.0073	T6	6 A (NO)	250 V AC	—	—	—
39.10.0.024.8273	T5	0.75 A	277 V AC	—	—	—
39.10.0.024.9073	T6	5 A	24 V DC	T5	4 A	24 V DC
39.11.8.230.0073	T6	6 A (NO)	250 V AC	—	—	—
39.10.8.230.8273	T5	0.75 A	277 V AC	—	—	—
39.10.8.230.9073	T6	5 A	24 V DC	T5	4 A	24 V DC
39.01.0.240.0073	T6	6 A (NO)	250 V AC	—	—	—
39.00.0.240.8273	T5	0.75 A	277 V AC	—	—	—
39.00.0.240.9073	T6	5 A	24 V DC	T5	4 A	24 V DC
39.11.7.024.0073	T6	6 A (NO)	250 V AC	—	—	—
39.11.7.024.8273	T5	0.75 A	277 V AC	—	—	—
39.10.7.024.9073	T6	5 A	24 V DC	T5	4 A	24 V DC
39.91.0.024.0073	T6	6 A (NO)	250 V AC	—	—	—
39.90.0.024.8273	T5	0.75 A	277 V AC	—	—	—
39.90.0.024.9073	T6	5 A	24 V DC	T5	4 A	24 V DC

Contact specification- Electromechanical Relay

F 39 - Electrical life (AC) v contact current

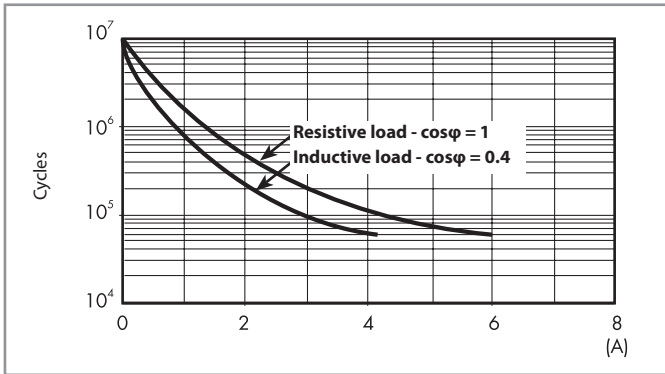

H 39 - Maximum DC1 breaking capacity

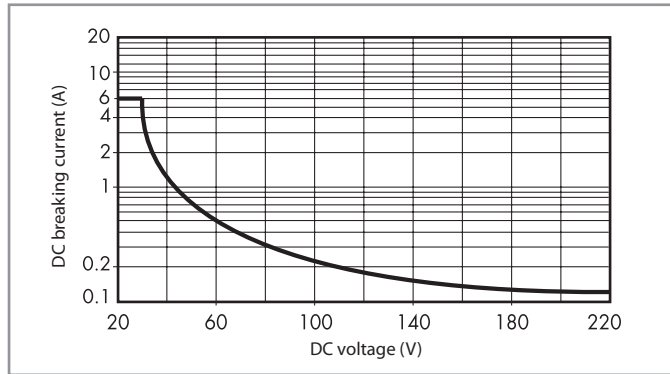

- When switching a resistive load (DC1) having voltage and current values under the curve, an electrical life of $\geq 60 \cdot 10^3$ can be expected.
- In the case of DC13 loads, the connection of a diode in parallel with the load will permit a similar electrical life as for a DC1 load.
Note: the release time for the load will be increased.

L 39 - Output current v ambient temperature

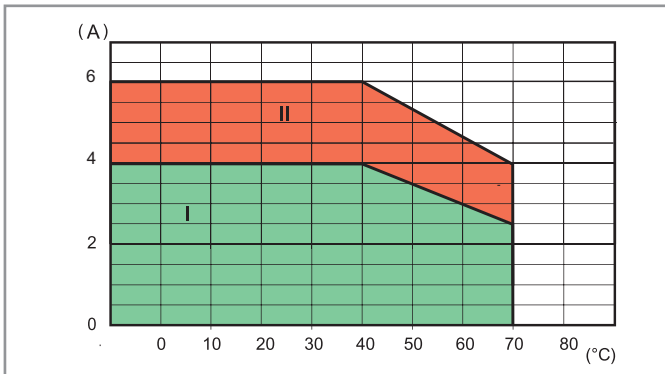

- I: 39 series installed as a group (without gap between sockets) with fuse module inserted
- II: 39 series installed as a group with "bridging" module, or individually with fuse module

Coil specifications - Electromechanical Relay

Coil data AC/DC - Types 39.11/01

Nominal voltage U_N	Coil code	Operating range		Must drop-out voltage U_r	Rated input current at U_N		Rated power at U_N
		U_{min}	U_{max}		I_N		
V		V	V	V	mA		VA/W
6	0.006	4.8	6.6	0.6	35		0.2/0.2
12	0.012	9.6	13.2	1.5	15		0.2/0.2
24	0.024	19.2	26.4	2.4	11		0.25/0.25
125 (110...125)	0.125	88	138	12.5	5.6		0.7/0.7
240 (24...240)	0.240	20.4	264	2.4	19		1.5/0.3

Coil data AC - Types 39.11/01

Nominal voltage U_N	Coil code	Operating range		Must drop-out voltage U_r	Rated input current at U_N		Rated power at U_N
		U_{min}	U_{max}		I_N		
V		V	V	V	mA		VA/W
230 (230...240)	8.230	184	264	23	4.3		1/0.4

Coil data AC/DC timer - Types 39.81/91

Nominal voltage U_N	Coil code	Operating range (AC/DC)		Must drop-out voltage U_r	Rated input current at U_N		Rated power at U_N	
		U_{min}	U_{max}		DC	AC	DC	AC
V		V	V	V	mA	mA	W	VA/W
12	0.012	9.6	13.2	1.2	15	23	0.2	0.3/0.2
24	0.024	19.2	26.4	2.4	11	19	0.25	0.4/0.3

Output specification - Solid State Relays

L 39-1 - Output DC current v ambient temperature

39.x0.x.xxx.9073

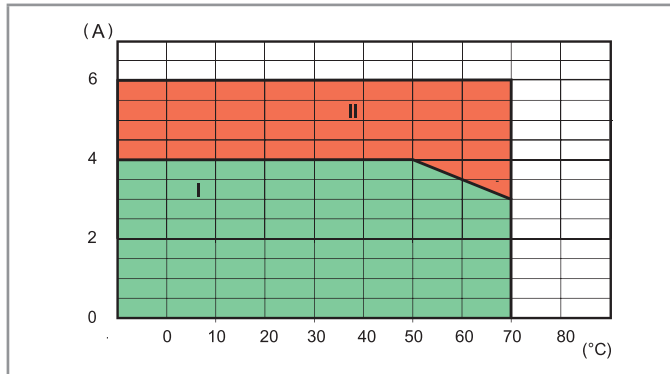

L 39-2 - Output AC current v ambient temperature

39.x0.x.xxx.8273

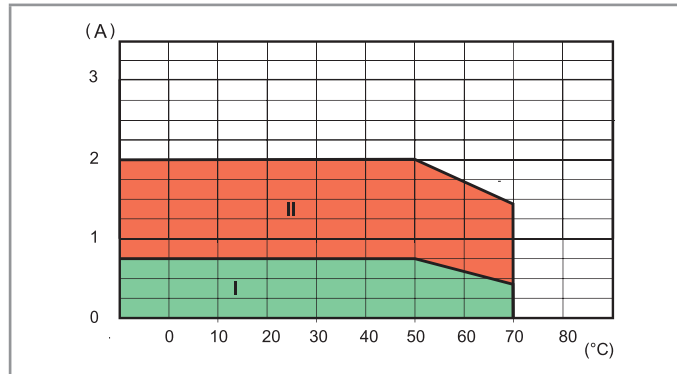

I: SSR installed as a group (without gap between sockets)

II: SSR installed individually in free air, or with a gap ≥ 9 mm, which implies a not significant influence from nearby components

Max recommended switching frequency (Cycles/Hour, with 50% Duty-cycle) at ambient temperature 50°C, single mounting

Load	39.x0.x.xxx.9073	39.x0.x.xxx.8273	39.x0.x.xxx.7073
24 V 6 A DC1	180 000	—	—
24 V 3 A DC L/R = 10 ms	5000	—	—
24 V 2 A DC L/R = 40 ms	3600	—	—
24 V 1 A DC L/R = 40 ms	6500	—	—
24 V 0.8 A DC L/R = 40 ms	9000	—	—
24 V 1.5 A DC L/R = 80 ms	3250	—	—
230 V 2 A AC1	—	60 000	—
230 V 1.25 A AC15	—	3600	—
48 V 0.1 A DC1	—	—	60 000

Input specifications - Solid State Relay

Input data AC/DC - Types 39.10/00

Nominal voltage U_N	Input code	Operating range		Must drop-out voltage U_r	Rated input current at U_N		Rated power at U_N
		U_{min}	U_{max}		I_N		
V		V	V	V	mA		VA/W
6	0.006	4.8	6.6	0.6	35		0.2/0.2
12	0.012	9.6	13.2	1.5	15		0.2/0.2
24	0.024	19.2	26.4	2.4	17.5		0.4/0.3
125 (110...125)	0.125	88	138	12.5	5.5		0.7/0.7
240 (24...240)	0.240	20.4	264	2.4	17.5		1.5/0.3

Input data AC - Types 39.10/00

Nominal voltage U_N	Input code	Operating range		Must drop-out voltage U_r	Rated input current at U_N		Rated power at U_N
		U_{min}	U_{max}		I_N		
V		V	V	V	mA		VA/W
230 (230...240)	8.230	184	264	23	4.2		1/0.4

Input data AC/DC timer - Types 39.80/90

Nominal voltage U_N	Input code	Operating range (AC/DC)		Must drop-out voltage U_r	Rated input current at U_N		Rated power at U_N	
		U_{min}	U_{max}		DC	AC	DC	AC
V		V	V	V	mA	mA	W	VA/W
12	0.012	9.6	13.2	1.2	15	23	0.2	0.3/0.2
24	0.024	19.2	26.4	2.4	11	19	0.25	0.4/0.3

Timer specifications

EMC specifications

Type of test		Reference standard	
Electrostatic discharge	contact discharge	EN 61000-4-2	4 kV
	air discharge	EN 61000-4-2	8 kV
Radio-frequency electromagnetic field	(80 ÷ 1000 MHz)	EN 61000-4-3	10 V/m
	(1400 ÷ 2700 MHz)	EN 61000-4-3	10 V/m
Fast transients (burst) (5-50 ns, 5 and 100 kHz)	on Supply terminals	EN 61000-4-4	4 kV
	on control signal terminals	EN 61000-4-4	4 kV
Surges (1.2/50 µs) on supply and control signal terminals	common mode	EN 61000-4-5	2 kV
	differential mode	EN 61000-4-5	0.8 kV
Radio-frequency common mode (0.15 ÷ 80 MHz)	on Supply terminals	EN 61000-4-6	10 V
	on control signal terminals	EN 61000-4-6	3 V
Radiated and conducted emission		EN 55022	class B

Other data

Bounce time (EMR): NO/NC	ms	1/6	
Vibration resistance (EMR, 10...55 Hz): NO/NC	g	10/15	
Power lost to the environment	without contact current	W	0.3
	with rated current	W	0.8

Terminals

		Box clamp	Push-in terminal
Wire strip length	mm	10	8
Screw torque	Nm	0.5	—
		Solid and stranded cable	Solid and stranded cable
Min. wire size	mm ²	1 x 0.5	1 x 0.5
	AWG	1 x 21	1 x 21
Max. wire size	mm ²	1 x 2.5	1 x 2.5
	AWG	1 x 14	1 x 14

Times scales



Functions

LED	Supply voltage	NO contact/output
	OFF	Open
	ON	Open
	ON	Open (timing to close in progress)
	ON	Closed

Wiring diagram

U = Supply voltage

S = Signal switch

= Output contact

Without control signal

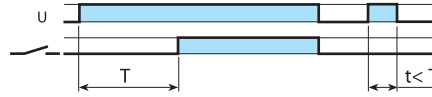
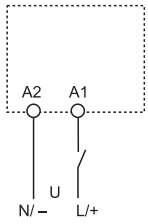

(AI) On-delay
Apply power to timer. Output contacts transfer after preset time has elapsed. Reset occurs when power is removed.

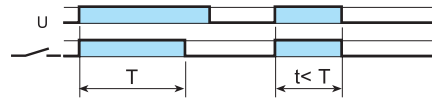

(DI) Interval
Apply power to timer. Output contacts transfer immediately. After the preset time has elapsed, contacts reset.

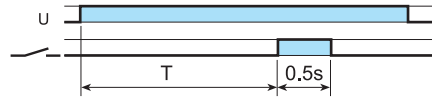

(GI) Pulse (0.5 s) delayed
Apply power to timer. Output contacts transfer after preset time has elapsed. Reset occurs after a fixed time of 0.5 s.

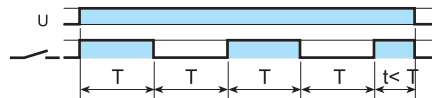

(SW) Symmetrical flasher (starting pulse on)
Apply power to timer. Output contacts transfer immediately and cycle between ON and OFF for as long as power is applied. The ratio is 1:1 (time on = time off).

With control signal

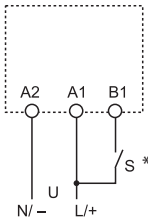

* With DC supply, positive polarity has to be connected to B1, terminal (according to EN 60204-1).

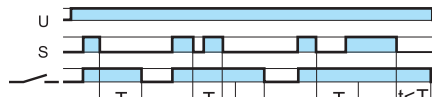

(BE) Off-delay with control signal
Power is permanently applied to the timer. The output contacts transfer immediately on closure of the Signal Switch (S). Opening the Signal Switch initiates the preset delay, after which time the output contacts reset.

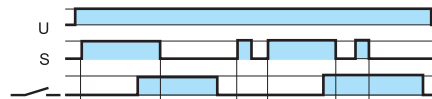

(CE) On- and off-delay with control signal
Power is permanently applied to the timer. Closing the Signal Switch (S) initiates the preset delay, after which time the output contacts transfer. Opening the Signal switch initiates the same preset delay, after which time the output contacts reset.

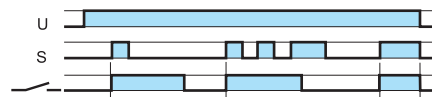

(DE) Interval with control signal on
Power is permanently applied to the timer. On momentary or maintained closure of Signal Switch (S), the output contacts transfer, and remain so for the duration of the preset delay, after which they reset.



(EE) Interval with control signal off
Power is permanently applied to the timer. On opening of the Signal Switch (S) the output contacts transfer, and remain so for the duration of the preset delay, after which they reset.

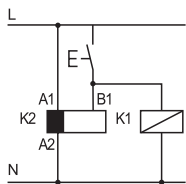

• Possible to control an external load, such as another relay coil or timer, connected to the control signal terminal B1.

** A voltage other than the supply voltage can be applied to the command Start (B1), example:
A1 - A2 = 24 V AC
B1 - A2 = 12 V DC

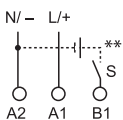

Outline drawings - Box clamp sockets

Types 39.10/39.11
Box clamp

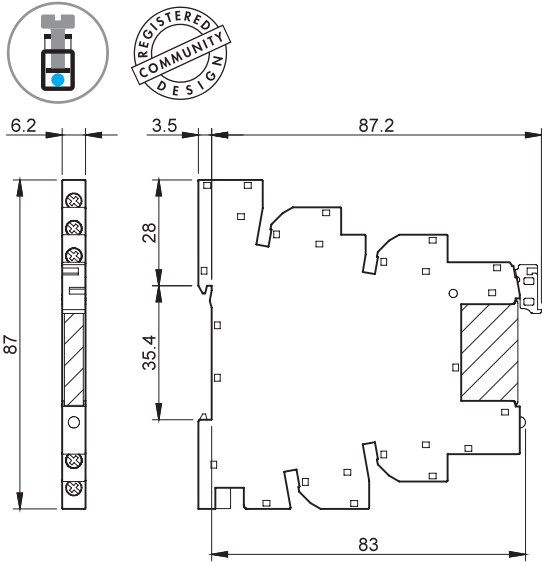

Types 39.80/39.81
Box clamp

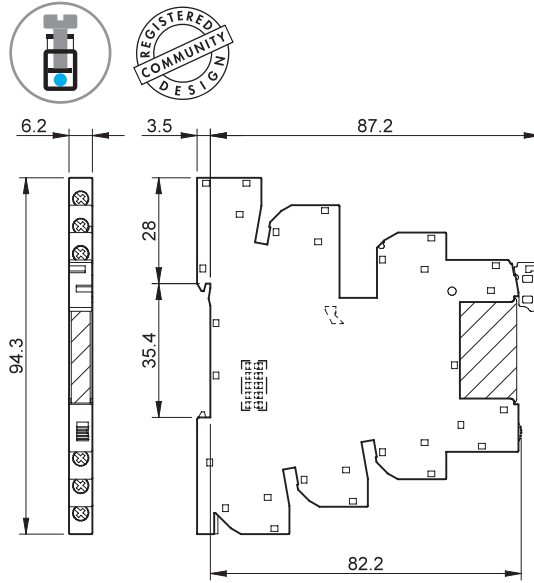

Outline drawings - Push-in terminal sockets

Types 39.00/39.01
Push-in terminal

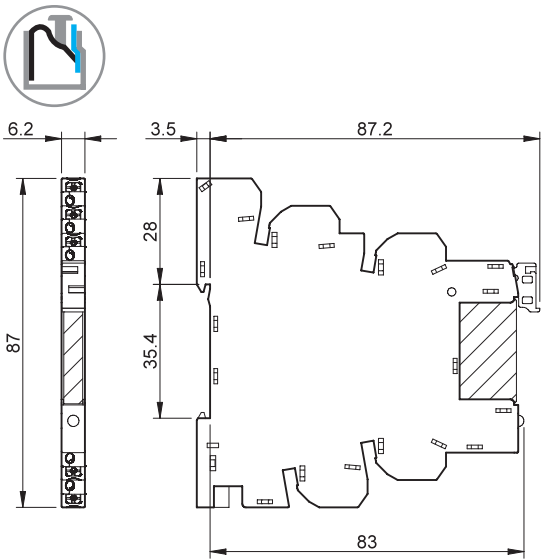

Types 39.90/39.91
Push-in terminal

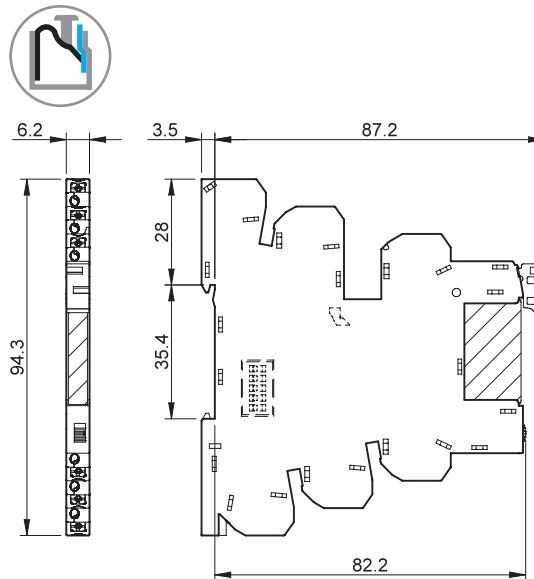

Main features

Push-in terminals

The push-in terminals permit the quick connection of solid wires or ferrules by their simple insertion into the terminal (A). It is possible to open the terminal to extract the wire by first pushing down on the push-button using a screwdriver (C). For stranded cable it is necessary first to open the terminal using the push button, both for the extraction (C) and insertion (B). It is possible at any time to check the connection via the test aperture, using a 2 mm diameter test probe (D).

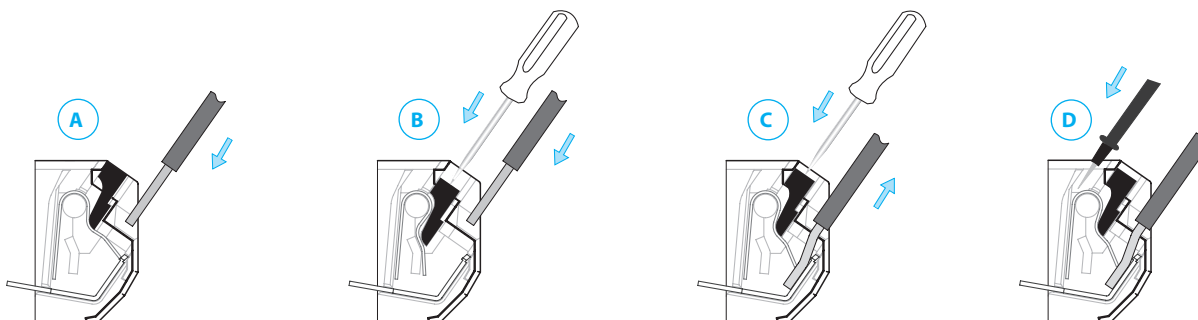

MasterBASIC ATEX/HazLoc - EMR version, Screw Socket Combinations

Interface Module Code	Coil voltage	Relay	Socket
<i>MasterBASIC ATEX</i>			
39.11.0.006.0073	6 V AC/DC	34.51.7.005.0000	93.61.0.024.7
39.11.0.012.0073	12 V AC/DC	34.51.7.012.0000	93.61.0.024.7
39.11.0.024.0073	24 V AC/DC	34.51.7.024.0000	93.61.0.024.7
39.11.0.125.0073	(110...125)V AC/DC	34.51.7.060.0000	93.61.0.125.7
39.11.0.240.0073	(24...240)V AC/DC	34.51.7.024.0000	93.61.0.240.7
39.11.8.230.0073	(230...240)V AC	34.51.7.060.0000	93.61.8.230.7

MasterBASIC ATEX/HazLoc - EMR version, Push-in Socket Combinations

Interface Module Code	Input voltage	Relay	Socket
<i>MasterBASIC ATEX</i>			
39.01.0.006.0073	6 V AC/DC	34.51.7.005.0000	93.60.0.024.7
39.01.0.012.0073	12 V AC/DC	34.51.7.012.0000	93.60.0.024.7
39.01.0.024.0073	24 V AC/DC	34.51.7.024.0000	93.60.0.024.7
39.01.0.125.0073	(110...125)V AC/DC	34.51.7.060.0000	93.60.0.125.7
39.01.0.240.0073	(24...240)V AC/DC	34.51.7.024.0000	93.60.0.240.7
39.01.8.230.0073	(230...240)V AC	34.51.7.060.0000	93.60.8.230.7

MasterTIMER ATEX/HazLoc - EMR version, Screw Socket Combinations

Interface Module Code	Input voltage	Relay	Socket
<i>MasterTIMER ATEX</i>			
39.81.0.012.0073	12 V AC/DC	34.51.7.012.0000	93.68.0.024.7
39.81.0.024.0073	24 V AC/DC	34.51.7.024.0000	93.68.0.024.7

MasterTIMER ATEX/HazLoc - EMR version, Push-in Socket Combinations

Interface Module Code	Input voltage	Relay	Socket
<i>MasterTIMER ATEX</i>			
39.91.0.012.0073	12 V AC/DC	34.51.7.012.0000	93.69.0.024.7
39.91.0.024.0073	24 V AC/DC	34.51.7.024.0000	93.69.0.024.7

MasterBASIC HazLoc - SSR version, Screw Socket Combinations

Interface Module Code	Input voltage	Relay	Socket
<i>MasterBASIC HazLoc</i>			
39.10.0.006.yy73	6 V AC/DC	34.81.7.005.xxxx	93.61.0.024.7
39.10.0.012.yy73	12 V AC/DC	34.81.7.012.xxxx	93.61.0.024.7
39.10.0.024.yy73	24 V AC/DC	34.81.7.024.xxxx	93.61.0.024.7
39.10.0.125.yy73	(110...125)V AC/DC	34.81.7.060.xxxx	93.61.0.125.7
39.10.0.240.yy73	(24...240)V AC/DC	34.81.7.024.xxxx	93.61.0.240.7
39.10.8.230.yy73	(230...240)V AC	34.81.7.060.xxxx	93.61.8.230.7

MasterBASIC HazLoc - SSR version, Push-in Socket Combinations

Interface Module Code	Input voltage	Relay	Socket
<i>MasterBASIC HazLoc</i>			
39.00.0.006.yy73	6 V AC/DC	34.81.7.005.xxxx	93.60.0.024.7
39.00.0.012.yy73	12 V AC/DC	34.81.7.012.xxxx	93.60.0.024.7
39.00.0.024.yy73	24 V AC/DC	34.81.7.024.xxxx	93.60.0.024.7
39.00.0.125.yy73	(110...125)V AC/DC	34.81.7.060.xxxx	93.60.0.125.7
39.00.0.240.yy73	(24...240)V AC/DC	34.81.7.024.xxxx	93.60.0.240.7
39.00.8.230.yy73	(230...240)V AC	34.81.7.060.xxxx	93.60.8.230.7

MasterTIMER HazLoc - SSR version, Screw Socket Combinations

Interface Module Code	Input voltage	Relay	Socket
<i>MasterTIMER HazLoc</i>			
39.80.0.012.8273	12 V AC/DC	34.81.7.012.8240	93.68.0.024.7
39.80.0.024.8273	24 V AC/DC	34.81.7.024.8240	93.68.0.024.7
39.80.0.012.9073	12 V AC/DC	34.81.7.012.9024	93.68.0.024.7
39.80.0.024.9073	24V AC/DC	34.81.7.024.9024	93.68.0.024.7

MasterTIMER HazLoc - SSR version, Push-in Socket Combinations

Interface Module Code	Input voltage	Relay	Socket
<i>MasterTIMER HazLoc</i>			
39.90.0.012.8273	12 V AC/DC	34.81.7.012.8240	93.69.0.024.7
39.90.0.024.8273	24 V AC/DC	34.81.7.024.8240	93.69.0.024.7
39.90.0.012.9073	12 V AC/DC	34.81.7.012.9024	93.69.0.024.7
39.90.0.024.9073	24 V AC/DC	34.81.7.024.9024	93.69.0.024.7

Example:

- .yy
- .9073 (5A - 24 V DC)
- .8273 (0.75 A - 230 V AC)
- .xxxx
- .9024
- .8240

Accessories



093.16



093.16.0



093.16.1

Approvals
(according to type):



093.60



16-way jumper link	093.16 (blue)	093.16.0 (black)	093.16.1 (red)
Rated values	36 A* - 250 V		

Possibility of multiple connection, side by side

* Maximum rating of the jumper link. Each individual pole shall not exceed the 6 A limit of the interface to which it is connected.

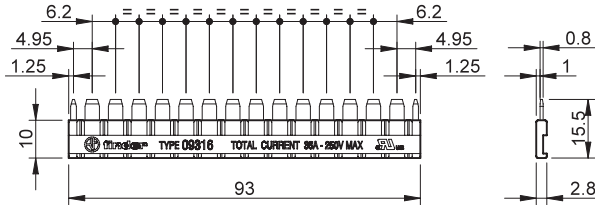

Dual-purpose plastic separator (1.8 mm or 6.2 mm separation)	093.60
---	--------

1. By breaking off the protruding ribs (by hand), the separator becomes only 1.8 mm thick; useful for the visual separation of different groups of interfaces, or necessary for the protective separation of different voltages of neighbouring interfaces, or for the protection of cut ends of jumper links.

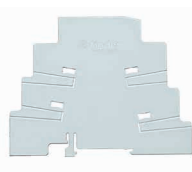

2. Leaving the ribs in place provides 6.2 mm separation. Simply cutting (with scissors) the relevant segment(s) permits the interconnection across the separator of 2 different groups of interface relays, using the standard jumper link.

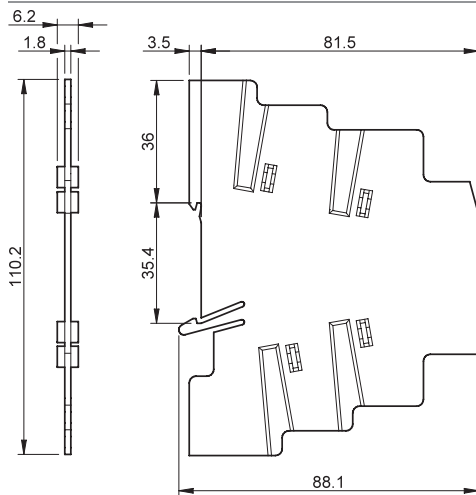
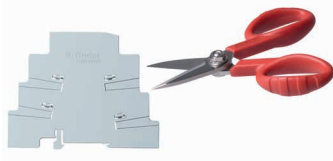

Sheet of marker tags, plastic, 48 tags, 6 x 10 mm	093.48
--	--------

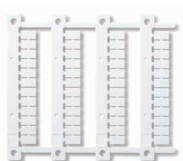

093.48

Sheet of marker tags (CEMBRE Thermal transfer printers), 48 tags, 6 x 12 mm	060.48
--	--------

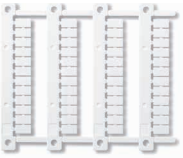

060.48

Accessories



093.68.14.1

Approvals
(according to type):

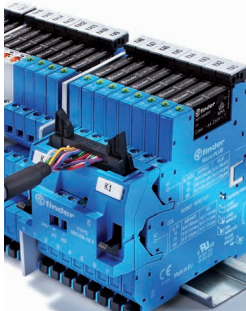

Connected *MasterADAPTER*

MasterADAPTER	093.68.14.1
----------------------	-------------

The *MasterADAPTER* permits the easy connection of A1/A2 terminals of up to 8 *MasterINTERFACE* modules to PLC outputs via a 14-Pole ribbon cable, plus simple 2-wire power supply connection ATEX Version.

Technical data

Rated current (per signal path)	A	1
Minimum required supply power	W	3
Nominal voltage (U _N)	V DC	24
Operating range	(0.8...1.1)U _N	
Control logic	Positive switching (to A1)	
Power supply status indication	Green LED	
Ambient temperature range	°C	-40...+70

Terminals for 24 V control logic

Type of connector	14 pole, according to IEC 60603-13
ATEX version	II 3G Ex nA IIC Gc

Terminals for 24 V power supply

Wire strip length	mm	9.5
⊕ Screw torque	Nm	0.5
	Max. wire size	
solid wire	mm ²	1 x 4 / 2 x 1.5
	AWG	1 x 12 / 2 x 16
stranded wire	mm ²	1 x 2.5 / 2 x 1.5
	AWG	1 x 14 / 2 x 16

Wiring diagram

