

RB Series
Bistable relay



Bistable relay for control and signaling
Type RB.14 - direct 35 mm rail (EN 60715)
Type RB.22 - for use with socket type 90.21

For use in the energy and railway sectors

- Type RB.14: 4 changeover contacts 8 A, modular, direct 35 mm rail (EN 60715) mount
- Type RB.22: 2 changeover contacts 8 A, plug-in, for use with socket type 90.21
- Nominal supply voltage: 24 - 110...125 - 220...250 V DC
- 2 coil type
- Manual SET and RESET on the product or remote via terminals
- LED indicators green / red for current (SET and RESET)

Approvals



Bistable relay for control and signaling

Type RB.14.9.xxx.0000
4 changeover contacts 8 A,
modular, direct 35 mm rail
(EN 60715) mount

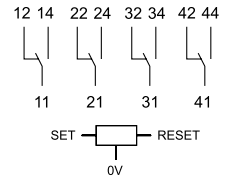
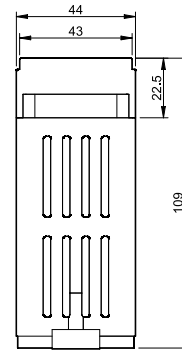
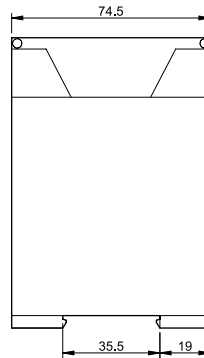

Connection for only local
push-buttons enable
EN = Enable - Positive voltage
0 V = Negative voltage

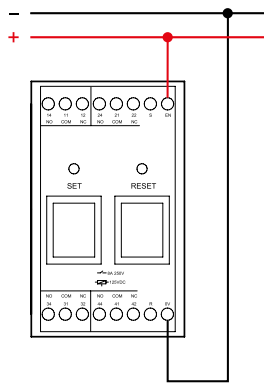

Connection for remote
push-buttons enable

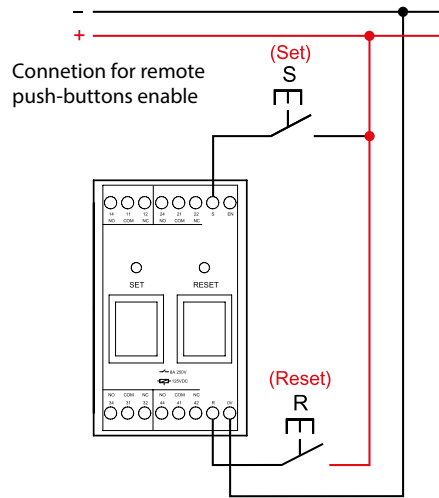

Connection for local
and remote
push-buttons enable

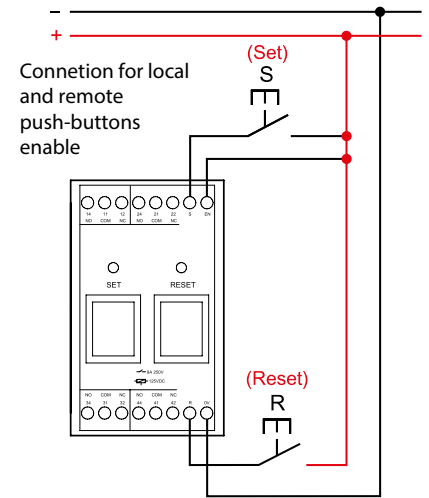

Tipò RB.22.9.xxx.9021
2 changeover contacts 8 A,
plug-in, for use with socket
type 90.21 (screw terminal -
Box clamp)

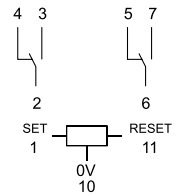
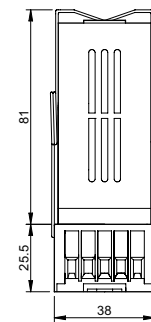
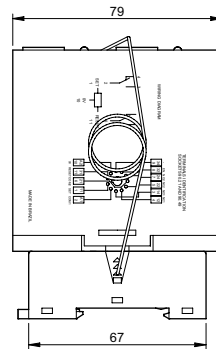

Connection for only
local push-buttons
enable
EN = Enable -
Positive voltage
0 V = Negative
voltage

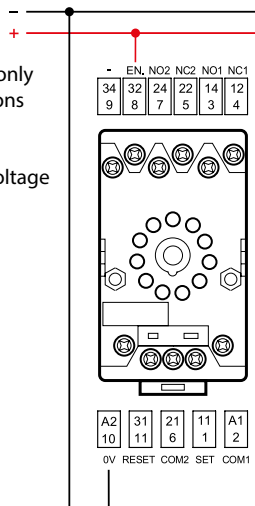

Connection for remote push-buttons enable

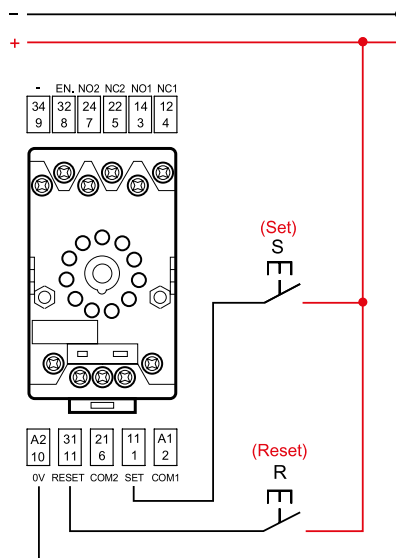

Connection for local and remote push-buttons enable

